

# GMV ATM

## Installation & Operating Guide.



# INDEX

	Page #
Brush pack.....	15
Crate contents.....	5
Electro magnetic clutch.....	15
Feed port plate.....	4
Greasing.....	17
Guide rail for doubles.....	14
Height adjustment.....	14
Installation.....	6
Inner retainer wheels.....	19
Introductions.....	1
Loading targets (installation).....	6
Magazine lock assembly.....	12
Main electrical box.....	14
Main safety release.....	4
Moving equipment.....	18
Notes (personal).....	18
Operating features.....	10 - 17
Outer retainer wheel assembly.....	16
Personal safety.....	3
Preventative maintenance.....	17
Release cord.....	13
Safety equipment.....	3 & 4
Safety precautions.....	3
Side adjustment hub.....	12
Spring tension.....	8
Target guide rail for singles.....	10
Target travel distance (installation).....	6
Throwing arm.....	10
Throwing singles (installation).....	6
Throwing doubles (installation).....	6
Trap house drawings.....	9
Trouble shooting.....	19 - 21
Trigger release assembly.....	16
Turn buckle.....	14
U-bracket.....	14
Unpacking the equipment.....	5
Warranty.....	2
Windage adjustment assembly.....	13

## INTRODUCTIONS

This instruction manual is designed to assist you in properly installing and operating this equipment. *All personnel **must** read this manual very carefully prior to the installation and usage of this equipment.*

This manual needs to be easily accessible to all personnel that will be using and/or servicing this equipment.

It is also important that you:

- Keep this manual for the lifetime of this equipment.
- Maintain records in this manual regarding any and all upgrades and all changes made to the equipment by the manufacturer.

**Carfully observe the information regarding the dangers, warnings, cautions and other notices mentioned throughout this manual and obey all warning signs placed on the equipment.** *Serious personal injury as well as machine failure may occur if you do not pay serious attention to the safety information.*

### **Manufacturer:**

**GMV Super Star AB**  
Box 256  
S-73224 Arboga  
Sweden  
Phone +46-(0)589-85550 Fax +46-(0)589-611997  
E-mail [gmvarboga.com](mailto:gmvarboga.com)

### **Responsibilities:**

**The manufacturer denies any and all responsibility for any breakage of the equipment or any personal injury resulting from abuse or from the failure of following the instructions in this manual. This manual sets out the authorized instructions on how to use this equipment.**

### **Importer:**

Quality Replacement Parts, Inc.  
9099 Bank Street, Suite B  
Valley View, OH 44125  
USA  
Phone 800-742-0425  
E-mail [sales@qualityreplacementparts.com](mailto:sales@qualityreplacementparts.com)

**Warranty:**

**GMV SUPER STAR CLAY TARGET THROWERS LIMITED WARRANTY.**

For two (2) years from the original date of purchase, GMV SUPER STAR will repair any defects in material or workmanship on **PARTS ONLY**. These defects must be determined to be so by our own examination.

The owner shall, at his own expense and risk, return the machine or defective parts to the North America Importer G H Enterprises Ltd, with all transportation charges to be prepaid.

All replacement parts will be FOB the North America importer G H Enterprises Ltd. or our GMV SUPER STAR dealer. We shall not be liable for any drayage or labor costs.

**This limited warranty is in addition to any statutory warranty.**

We do not authorize any person or representative to make any other warranty, or assume for us any liability, other than those contained herein. Any agreement outside of or contradictory to the foregoing shall be void and of no effect. The free parts replacement portion of this warranty applies only to the GMV SUPER STAR clay target throwers owned and operated in North America.

The following are **not** considered defects and are **not** included in the warranty:

1. Damage resulting from an improper line of voltage;
2. Service required from damage due to misuse or abuse;
3. Service required from accidents, alteration, fire, flood or Acts of God; and
4. Service required to regular wear parts such as service cords, throwing arms, reed switches, target retainer O-rings and brushes.

*The warranty registration card must be returned to GH Enterprises Ltd. within 30 days of purchased or the warranty is null and void.*

**THIS LIMITED WARRANTY ENDS AND OUR RESPONSIBILITY CEASES** if any alterations are made to the machine, if the serial number is mutilated, altered or removed or if any parts or devices not manufactured or distributed by GMV SUPER STAR are added to the working mechanism of the machine.

**GMV Super Star**  
Norra Agatan, Box 256  
73224 Arboga Sweden

## **SAFETY PRECAUTIONS:**

The following warnings must be followed to ensure the safety of all persons operating an/or repairing the equipment:

**WARNING!** The equipment must be bolted down on a secure base when in use!

- *Shut off the power with the main safety release (picture # 3) during all stoppages.*
- Observe all electrical equipment as being current carrying.

**Warning!** When performing service and maintenance on the equipment **turn the power off using the main safety release (picture # 3). Disconnect the main power supply as well as the circuit breaker.**

**Release the spring tension using the spring tension release bolt. Make sure the machine is uncocked.** (picture # 20).

- **Important!** *This equipment is intended for 115-volt use only. Note the amperage written on the motors.*
- **Important!** *This equipment is made with metric sized screws, bolts and nuts.*

*Please note and follow the warnings written below.*

**Danger!** Ignoring this information may result in immediate danger.

**Warning!** Ignoring this information is associated with extreme danger or serious personal injury,

**Careful!** Ignoring this information may result in minor personal injury or equipment failure.

**Important!** This information needs extra attention.

## **SAFETY EQUIPMENT:**

**Warning!** The safety equipment's functions should be checked often. Check that the main safety release (picture # 3) is working properly.

**Warning!** Only qualified personnel should assemble, disassemble and transport the equipment.

## **PERSONAL SAFETY :**

**Danger!** Every person involved with the set up, service, maintenance and daily operation of this equipment must read and follow the safety precautions contained in this manual.

**Warning!** No persons or loose objects should be kept within the danger area (see picture # 29). By staying within the danger area, the risk of personal injury from moving parts, as well as a risk of being hit by clay targets, can occur.

**Warning!** Entry into the trap house is allowed only after the electricity to the machine is turned off using the main safety release (picture #3).

**Warning!** The safety guard (picture # 1) must always be mounted on the machine when the machine is in use.

**Warning!** The spring tension (picture # 20) must be released before any work can be performed on the machine.



Safety guards.  
Picture # 1

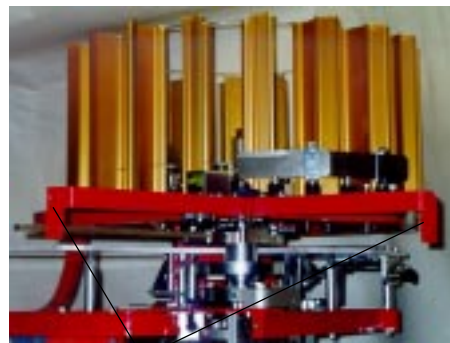

Safety guards brackets. Picture # 2

### Main safety release:

**Warning!** The main safety release (picture #3) shall be positioned in an appropriate location outside of the danger area.

**Warning!** After every use, shut off the power to the machine using the main safety release.

*The main safety release is GMV Super Star's unique ON/OFF switch.*

*In the ON position it starts the main cocking motor with a slight delay.*

*In the OFF position the power is turned off and the throwing arm is uncocked.*

**Warning!** When the main safety release is turned to the OFF position, one or two targets (depending on which mode the machine is set in) will be released. Make sure there are no personnel in the danger area (picture # 29) when turning the power off.

### Main safety release.



Picture # 3

**UNPACKING:**

- Remove all packing materials including the transportation bracket from the equipment.
- Check for any visual damage to the equipment.
- If any damage has occurred to the equipment during shipping, please contact the Transport Company as well as your GMV SUPER STAR dealer.

- The machine must only be lifted and moved using the enclosed lift handles! (picture #5)**
- Serious damage may occur to the machine otherwise!**
- Please make sure that the following parts are included with the machine (picture # 4)

Crate Contents

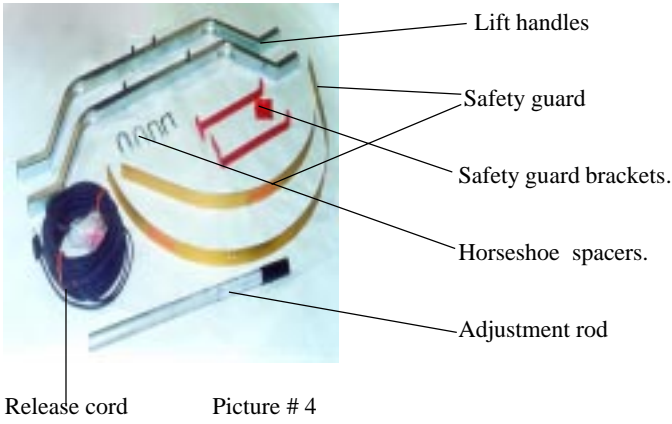

## INSTALLATION:

**WARNING! Only qualified personnel shall perform all installation as per this manual!**

**Important! All nuts, bolts and screws are metric sized. Please make sure that you use metric tools for assembly and repair of the machine.**

### Assembly and installation:

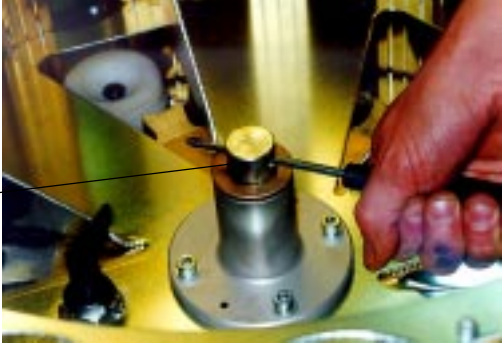
1. Remove the transportation bracket.
2. With a screwdriver through the hole in the magazine shaft, unscrew the shaft. 
3. Lift off the magazine.
4. Move the machine into the trap house **using the lift handles only** (picture # 5). **Damage may occur to the machine otherwise.**
5. Place the machine on the pedestal. Remove the lift handles (picture # 5) and loosely tightening the machine to the pedestal **Do not leave it unfastened, it may tip.**
6. Center the machine in the house by measuring from the front screw on the pull cord connector box (picture # 18). This location should be 12 inches to the left of the centerline (looking from the back of the machine).
7. Reinstall the magazine.
8. Install the throwing arm (picture #6).
9. Install the safety guard (picture # 2).
10. Set the feed port in the loading position (picture # 12).
11. Unlock the magazine lock assembly (picture # 13) The magazine is now free spinning.  
*The magazine may only be turned clockwise!*



12. Load 5 – 6 targets into each of the target columns. Turn the magazine lock assembly knob back to the locked position (picture #13) and move the magazine clockwise until it locks into place.
13. Set the single guide rail into the single position by moving the single guide rail knob upwards (picture # 8).
14. Open the feed port to the single position by rotating the feed port knob counterclockwise (front hole open - picture # 10). **One or more targets will drop to the throwing table when you turn the feed port. Make sure to remove them from the throwing table.**
15. Set the machine in the center hole by unscrewing the thumbscrew and moving it to the center hole on the side movement adjustment hub (picture # 14). **Important! Clean the area around the machine by removing all target boxes, tools etc.!!!**
16. Plug the pull cord into the pull cord connector box (picture # 18). **Danger! Make sure all persons have moved away from the danger area!!!** (picture #29)
17. Plug the main power cord into a grounded electric outlet.
18. Turn the power on using the main safety release (picture #3). *A slight delay occurs from the time the motor starts until the arm is cocked. BE AWARE!*
19. Throw targets.
20. If you have a curl showing in an airborne target adjust as follows:  
**Make sure no persons are within the danger area. Turn the power off using the main safety release.** Move the U-bracket using the adjustment bolt. Move it up if the target curls to the right and down if the target curls to the left (picture # 22).
21. Check for the length and the angle of the targets. In this position (center hole on the side movement adjustment hub picture # 14), the targets should be straight aways. If not move the adjustment arm on the windage assembly until you have a perfect straight away target.
22. Tighten the screws, securely fastening the machine onto the base.
23. To adjust the distance travelled by the targets, use the spring tension adjustment (picture #19). If the target travel distance is too short, put the spring tension adjustment rod into the eyelet, pull the eyelet out with the rod and add as many of the horseshoe spacers as needed.
24. If the target travel distance is too long, follow same procedure as for the previous adjustment, removing as many horseshoe spacers as needed.
25. If you need to change the elevation of the target flight path do so by using the turnbuckle (picture # 21).

26. To set the machine for doubles, move the single target guide rail down (picture # 8). Move the feed port counterclockwise until two holes are open (picture # 11). Make sure there is no target debris on the throwing table. The machine is now ready to throw doubles.
27. **Make sure there are no persons within the danger area. Turn the power on using the main safety release. Throw a few pairs.**
28. To adjust the travel distance of the targets when throwing doubles, you use the same procedure as when you adjust for the singles. (See paragraph 22 & picture # 19).
29. To level the pair in the air turn the double guide rail knob (picture # 24). If the right target is too high turn the knob clockwise and if it is too low turn the knob counterclockwise. If this adjustment is not enough, use the U-bracket for additional adjustment (picture # 22).
30. The field adjustment of the targets is done by using the windage adjustment (picture # 16). Lift the windage adjustment knob upwards and hold, moving the machine left or right one hole at a time until the correct field adjustments are done.
31. ***Your GMV ATM is now ready for action!***

***All the above adjustments do not take into consideration weather conditions.***

**If after following the above directions the machine does not work properly, please see the trouble shooting section at the back of this manual.**

# GMV/SUPERSTAR MODEL AT HOUSE PLANS

12-27-99

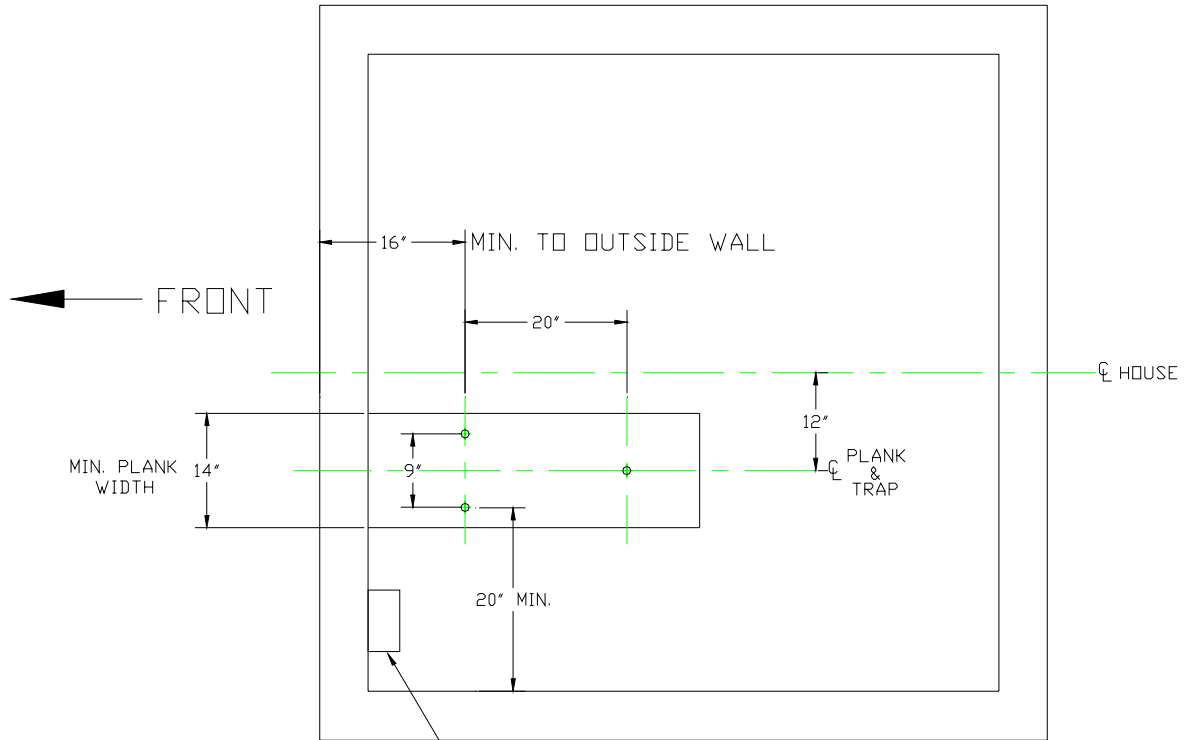

RECOMMENDED LOCATION FOR POWER RECEPTACLE  
(115 VOLT/15 AMP POWER SUPPLY  $\perp$ )

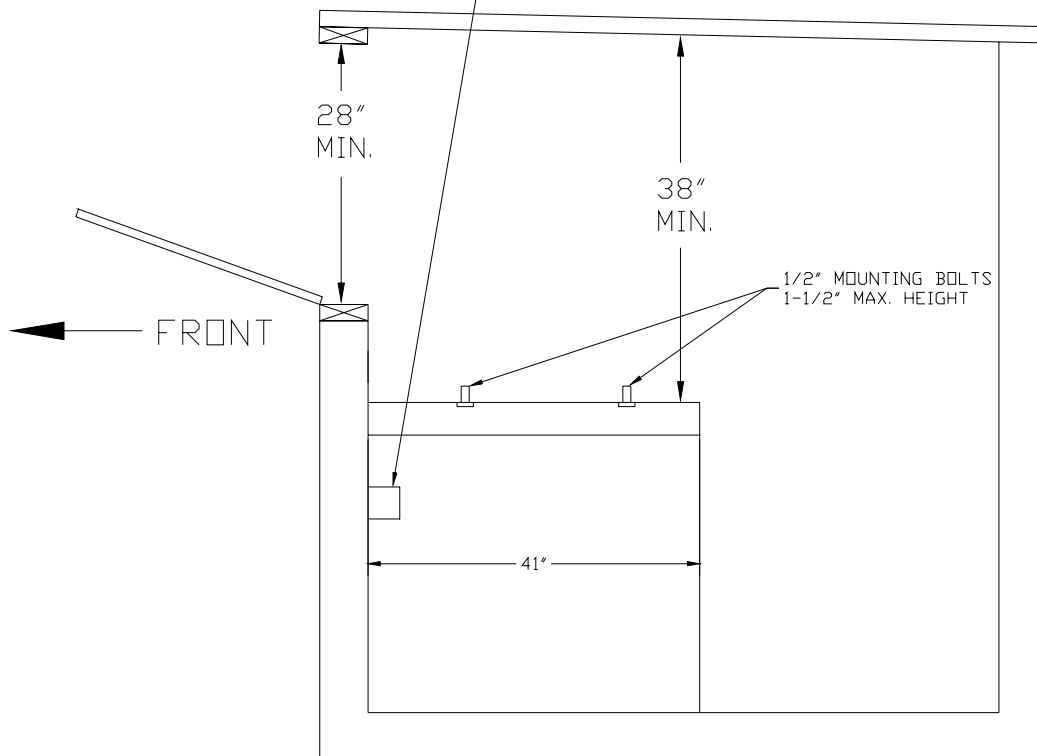

## OPERATING FEATURES:

### 1. **Throwing arm:**

Avoid using the machine without targets as this will result in greater stress on the throwing arm.

After extended use the throwing arm may become fatigued and the neoprene edge worn. Check the throwing arm often and replace it when necessary.

To replace:

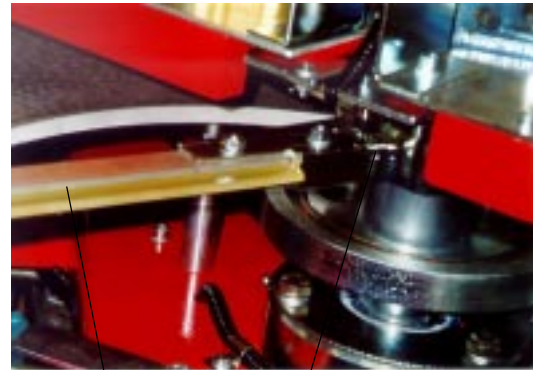

Throwing arm Throwing arm holder Picture # 6

**WARNING! Make sure no persons are within the danger area.**

**SHUT OFF THE POWER WITH THE MAIN SAFETY RELEASE!** (picture # 3)

**Release the spring tension by turning the allen bolt located on the spring tension release rod (picture # 20). Make sure the machine is uncocked.**

Loosen the screws on the throwing arm holder.

Pull the throwing arm free.

Replace the throwing arm and securely tighten the screws.

Make sure the arm is securely fastened.

To adjust the height of the throwing arm, loosen the allen bolt on the throwing arm holder then move the arm up or down as required.

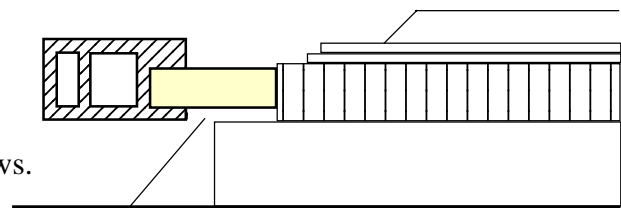

Picture # 7

The distance between the neoprene on the throwing arm and the first rim of the clay target should be 1/32" (1mm).

### 2. **Target guide rail for singles:**

The target guide rail for singles nests the target between the throwing table, the target guide rail and the throwing arm.



Target guide rail adjustment for singles Picture # 8

*Move the target guide rail lever up for singles*

*Move the target guide rail lever down for doubles.*

*Move the target separator knob in for singles*

*Move the target separator knob out for doubles.*



Picture # 9

### 3. **Feed port plate:**

The feed port plate is adjustable three ways by turning the feed port plate counter clockwise only.

- a. **Singles:** The front hole on the feed port plate is in the open position. This way only one target will be loaded onto the elevator and lowered to the throwing table.

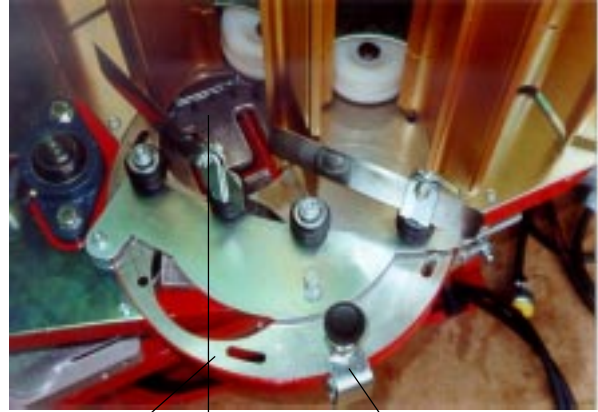

Feed port plate | Feed port lock assembly | Picture # 10  
Feed port in single position

- b. **Doubles:** Both of the holes on the feed port plate are in the open position. This way two targets will be loaded onto the elevators and lowered to the throwing table.

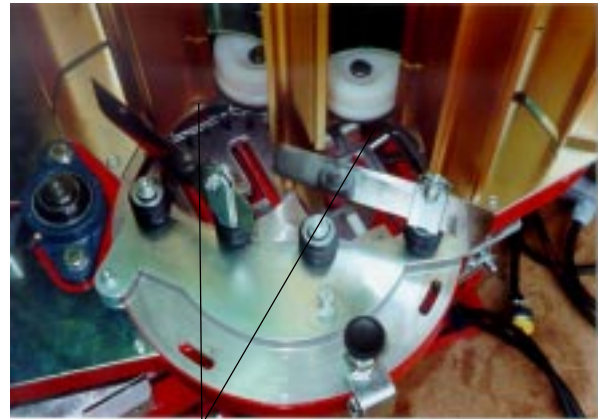

Feed port in double position | Picture # 11

- c. **Loading:** Both of the holes on the feed port plate are placed in the closed position, away from the target stacks. This way no targets are loaded onto the elevators, making it possible to free spin the target magazine when loading targets.



Feed port in loading position | Picture # 12  
both target holes closed

4. **Magazine lock assembly:**

The magazine lock assembly when in the open position makes the magazine rotate freely for easy loading of the targets.

**CAREFUL!** *The magazine may only be rotated clockwise!*

**WARNING!** Before entering the trap house, turn off the power using the safety release ( picture # 3) and keep the power off while loading the magazine.

Stand behind the magazine and reach into it. Now, turn the lock assembly knob a half turn. The magazine is now unlocked and in this position it rotates freely. When the magazine is loaded, turn the lock assembly knob back to the locked position. **IMPORTANT!** Lock the magazine by turning it clockwise until it snaps into the locked position.

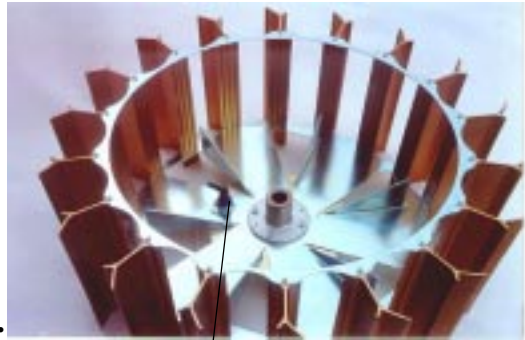

Magazine lock assembly. Picture # 13

5. **Side adjustment hub:**

**WARNING!** Turn off the power using the main safety release before entering the trap house and making this or any other adjustments on the equipment.

The adjustment hub is used to set the throwing angles of the targets. To set the angles, unscrew the thumbscrew and choose the angle hole desired (center, 1, 2, 3, 4, 5 or 6).

The center hole is used for straight aways and doubles. The remainder of the holes vary the throwing angles of the targets.

The ON / OFF switch for the oscillating motor is located on the side of the machine beside the target counter.

The switch positions are as follows: "0" is off, "1" turns on the oscillating motor and "2" keeps on the oscillating motor and turns on the height motor on wobble traps only.



Picture # 14  
Thumbscrew



Picture # 15

6. **Windage adjustment assembly:**

The windage adjustment assembly is to be used when the target field needs to be moved left or right because of weather conditions. To adjust, lift the windage adjustment knob upwards and hold. Move the machine left or right for the correction needed. Guide the knob into the appropriate hole. Make sure the knob is locked in.



Lock handle Thumbscrew Adjustment bolts Picture #

16

7. **Release cord:**

The release cord is part of the release system. The release cord is 100 ft. long and comes complete with a push button assembly. The release cord should be plugged into the release cord connector box located on the base plate on the front of the machine.

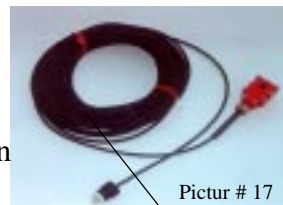

Pictur # 17  
Pull cord assembly



Picture # 18  
Pull cord connector box

8. **Spring tension:**

The spring tension adjustment is performed easily on your GMV ATM. Put the spring tension adjustment rod into the eyelet (located on the right rear corner of the machine), pull the eyelet out with the rod and add as many of the horse shoe spacers as needed to achieve the proper target travel distance. Four different sizes of horseshoes are included with the machine (2mm, 5mm, 10mm and 15mm).

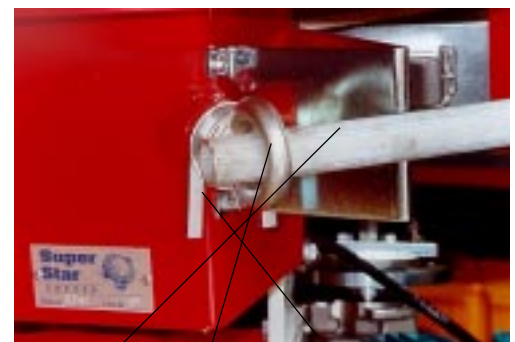

Spring tension rod Horseshoe Eyelet Picture # 19

**WARNING! Before working on the machine you must release the spring tension.** To do this you turn the spring tension release bolt until the spring tension releases.

**IMPORTANT! Before starting the machine** make sure the release tension bar is in the locked position by moving the throwing arm back and forth at the same time as you turn the spring tension release bolt until it is locked. When it is in the locked position the throwing arm can only be moved counterclockwise.

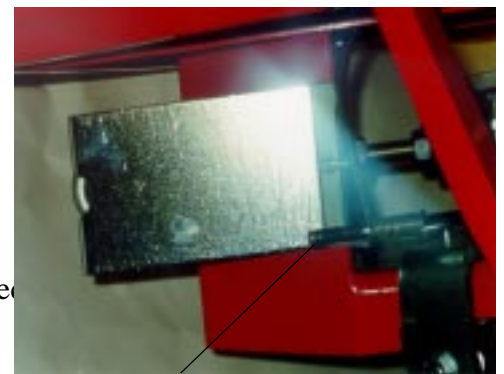

Spring tension release bolt. Picture # 20

9. **Turnbuckle:**

The turnbuckle is used to adjust the height of the target flight path. Turn the turnbuckle clockwise or counterclockwise until the desired elevation is achieved.

Turnbuckle

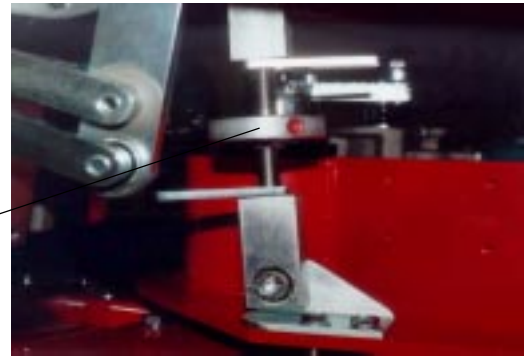

10. **U-Bracket:**

Use the U-bracket adjustment to remove any curl appearing in the target flight path, as well as to level off the flight path of the doubles pair. These adjustments are performed by loosening the two (2) lock bolts situated on the right (inside) of the U-bracket. After you have done this you then turn the adjustment bolt on the U-bracket (bottom center) up or down as needed for the correction of the flight path. After the adjustment is completed, tighten the lock bolts.

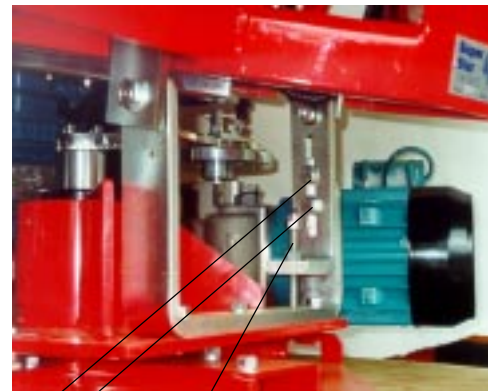

Lock bolts

Adjustment bolt

Picture # 22

11. **Guide rail for doubles:**

The function of the double guide rail is to nest the targets between the guide rail, the brush pack and the throwing arm. The guide rail is adjustable by using the guide rail adjustment knob located on the back of the throwing table. Turning the adjustment knob clockwise will lower the flight path of the right target and it will also move the field slightly right. Turning the adjustment knob counterclockwise will raise the flight path of the right target and it will move the field slightly left

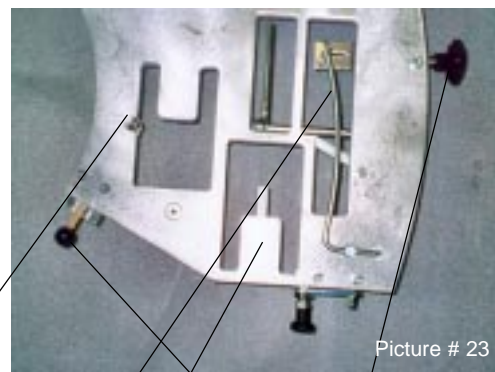

Picture # 23

Guide rail double

Adjustment knob for doubles

Throwing table Target separator knob

11A **Target Separator.**

The function of the target separator is to separate the Double targets when the targets are placed on the throwing table. It separates the targets and less pressure is used to move the targets forward beneath the brush pack. This means less friction between the targets and the guide rail, resulting in better target presentation.

*The separator knob should be pushed in for singles and pulled out for doubles.*

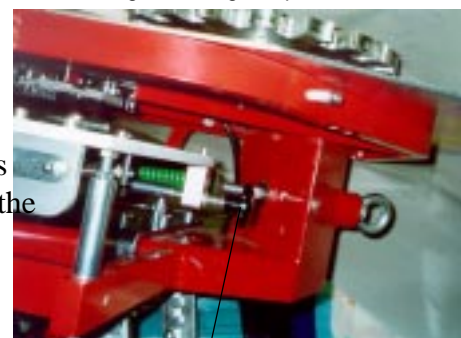

Adjustment knob for doubles.

Picture # 24



## 12. **Brush pack:**

The function of the brush pack is to nest the targets in the proper position. Place a target on the table just below the brush and loosen the brush pack release bolt. (Picture # 26) The brush pack will drop down and sit on top of the target. Now tighten the release bolt. Remove the target.

For both single and double targets the distance between the target rim and the neoprene on the throwing arm can be as much as 6.5 mm (1/4").

*If the distance between the target rim and the neoprene on the throwing arm is too great, the targets will break when thrown. The brush pressure is probably too loose, so readjust the brush pressure.*

*If the target breaks when the arm positions the target under the brush pack, the pressure of the brush pack is probably too high, so readjust the brush pressure.*

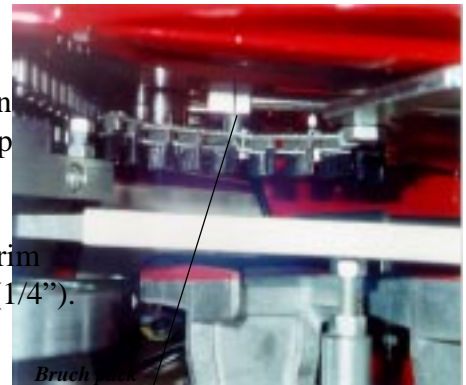

Brush pack

Picture # 25

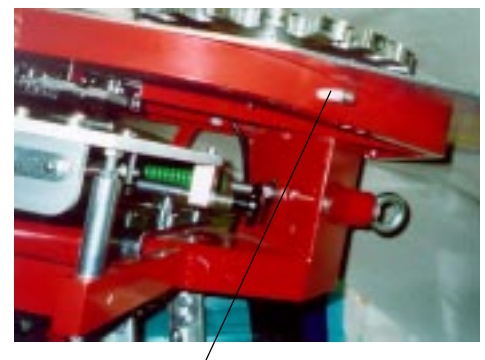

Brush pack release bolt Picture # 26

## 13. **Electro magnetic clutch**

The electric magnetic clutch cocks the machine. The clutch is located between the main motor and the gearbox. The distance between the rotor and the stator should be between 0.012" to 0.016". If the distance is less than this, the machine may start windmilling. If the distance is greater than this, the machine will not cock. To adjust the clutch, loosen the two setscrews situated on the gearbox-input shaft and then slide the clutch forward or backwards until the correct distance is obtained. Use a feeler gauge to obtain the correct distance.



Stator Rotor.  
Adjustment gap

Picture # 27

14. **Main electrical box:**

The main electrical box is the power supply source for both the 115V and the 24V machines. It also includes the interrupter and the safety release system. The electrical box operates on a quick-connect system for easy repair and troubleshooting.

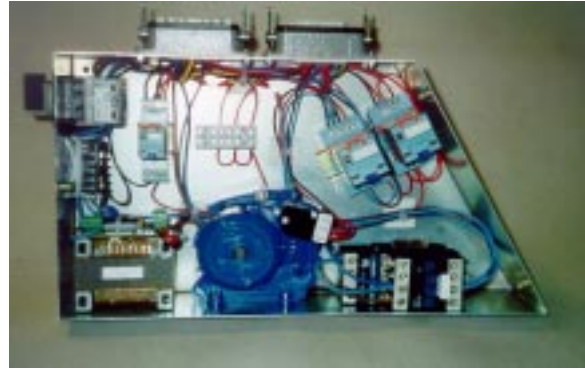

**WARNING! Before disconnecting the main electric box, make sure that no unauthorized personnel and no loose objects are present in the danger area! Shut the power off with the safety release and unplug the machine from the main power source.**

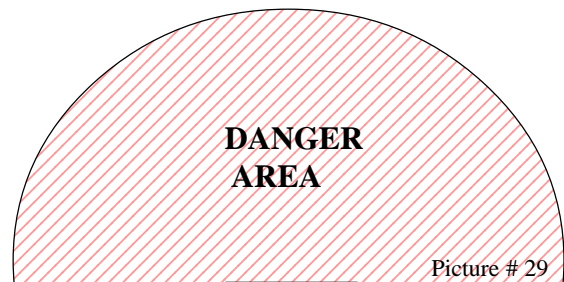

Picture # 29

Trap House

15. **Trigger release assembly:**

The trigger release assembly is GMV ATM's unique release system. The trigger release assembly consists of four (4) parts: the outer housing, an electro magnet, a sear and a sear plate. When the machine is cocked, the 24 volt electro magnet holds the sear plate closed. When the release button is pushed, a relay switches the current from the electro magnet to the electro magnetic clutch and cocks the machine.

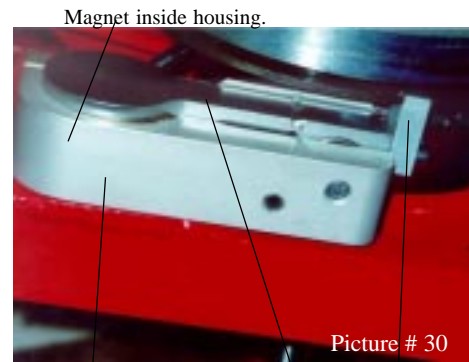

Picture # 30

Trigger assembly housing. Sear plate Sear.

16. **Outer retainer wheel assembly:**

The function of the outer retainer wheel assembly is to hold the targets in place as the magazine is turning. The outer retainer wheels should be adjusted for different sizes and makes of targets. To make a proper adjustment, load 4 – 5 targets in each of the magazine columns, close the feed port (picture #12) unlock the magazine lock assembly (picture #13), turn the magazine Slowly. The outer retainer wheels should barely touch the targets as the magazine is turning. To adjust, loosen the nuts on the underside of the retainer wheel assembly plate and slide the wheels in or out for a correct fit.

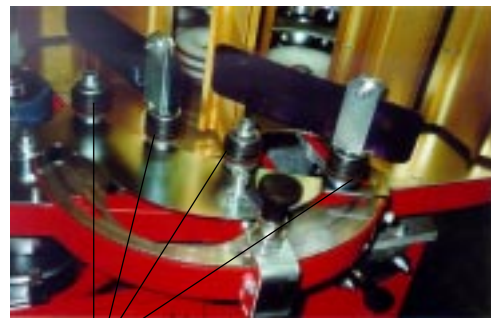

Outer retainer wheels.

Picture # 31

**19. Inner target retainer wheels:**

The function of the inner target retainer wheels is to hold the target stacks in place as the magazine is turning.

The wheels must turn freely. If they are stuck, two or more targets will drop onto the elevators, resulting in broken targets.

To adjust, remove the magazine (see installation paragraph # 2), remove the lock ring on top of the target retainer wheels and then lift off the target retainer wheels. Clean the inside of the holes on the target retainer wheels and the inner shafts. Grease with a very light oil (G96 or similar).

Now reassemble.



Target retainer wheels.

Picture # 32

**PREVENTATIVE MAINTENANCE:**

To ensure the long and trouble-free life of your machine, please perform the following maintenance at regular intervals.

At all times keep the machine and its surroundings clean and dry.

Please perform regular inspections and replace the following parts as needed:

- Throwing arm
- O-rings
- Target elevators
- Shock absorbers on the elevator.
- Release sear and trigger plate
- Brush pack

When replacement parts are required please contact your dealer.

**Greasing:**

Grease the following parts every 6 months, or earlier if necessary:



Geneva lock.

Picture # 33

Use a brush grease the surface with a light grease



Elevator cam

Picture # 34

Use a brush grease the surface with a light grease



Grease nipple

Main Bearing

Picture # 35

Grease the grease nipple once a year or 100000 targets,

Elevators and elevator plunger.

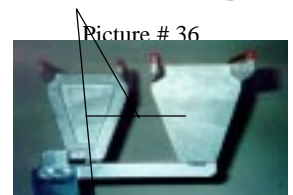

Picture # 36



Picture # 37 Throwing table.

Use a brush grease the surface with a light grease



## TROUBLESHOOTING GMV-ATM

If, after following all of the instructions contained in this manual you experience any problems, the following suggestions may be of some help. If you need further assistance please do not hesitate to contact GH Enterprises Ltd. by phone at (403) 938-6070, by fax at (403) 938-3206 or by email at [skeet@telusplanet.net](mailto:skeet@telusplanet.net)

PROBLEM	CAUSE	SOLUTION
<i>If the machine does not start</i>	No power	Check the power supply. If you have power, check the overload breaker situated on the side of the motor connector boxes. If there is no power, call an electrician.
<i>No target released</i>	Faulty release cord	Check the release cord with an Ohmmeter. If there is no resistance in one or more wires cut approximately two feet off the cord on the push button end, then re-connect the push button.
<i>No target released (15&amp;28) of the release</i>	Faulty relay	Remove the electrical box (picture # check the relay with the help button on the relay. If no target is released replace the relay.
<i>Broken targets</i>	Target pieces may stick in the elevator and on the throwing table.	Clear the throwing table and the elevator of any broken target pieces.
	<b>or</b>	
	The throwing arm is situated wrong	Adjust the throwing arm. (see picture #7)
	<b>or</b>	
	The throwing arm is bent	Replace the throwing arm (picture # 6)
	<b>or</b>	
	The target retainer wheels O-rings are damage. (2 wheels, 1 o-ring on each)	Check the O-ring on the inside target retainer wheels (inside the magazine stacks) if it is damaged replace it. (one on each wheel)

<b>PROBLEM</b>	<b>CAUSE</b>	<b>SOLUTION</b>
Broken targets	The target retainer wheels are not turning.	Remove the target magazine (Installation paragraph #2) and the retainer wheels. Clean the retainer wheel holes as well as the shaft, then oil with a light oil (G96). Now reassemble.
	<b>or</b>	
	The outer target retainer wheel assembly is adjusted too tightly.	Adjust the assembly as per paragraph # 19 picture #32
	<b>or</b>	
	Wet targets or different size and makes of targets are used in the same stack.	Remove the targets. Make sure to use only dry targets and to load each stack with the same make of targets.
<i>If the target breaks as the arm is coming into the cocked position (Single mode)</i>	The brush pack pressure is too high.	Adjust as per paragraph 12 (picture #25 & 26)
<i>If the target breaks as it is released</i>	The brush pack pressure is too low, making the target slide away from the throwing arm.	Adjust as per paragraph 12 (picture #25 & 26)
<i>If the targets breaks intermittently</i>	The throwing arm may be situated too low, squeezing the target against the throwing table	Adjust as per paragraph (#1 picture # 7)

*If the targets breaks when the arm comes into the cocked position (doubles mode)*

The single target guide rail may be set for singles

Lower the single target guide rail as per paragraph #2 (picture #8)

**or**

The double target guide rail may be situated too far forward

Adjust the double target guide rail as per paragraph #11 (picture #24)

**or**

The brush pack pressure may be too high

Adjust the brush pack pressure as per paragraph # 12 (picture #25 & 26)

*If the target angles are incorrect (single mode)*

The throwing arm is most likely set too low and is squeezing the targets against the throwing table

Adjust as per paragraph #1 (picture #7)

*The machine is throwing targets non-stop*

Faulty push button

Disconnect the release cord. If the machine stops throwing targets, change the push button switch.

**or**

Faulty clutch setting

Adjust the clutch by removing the cover plate located on the worm gears neck (gearbox). Set the clutch gap at a distance of 0.012” to 0.016”. If the distance is greater the machine will not cock and if smaller the machine will windmill. (paragraph #13 picture #27)

**or**

Target fragments stuck in the trigger release

Check for target fragments between the frame and the release assembly or check for fragments between the magnet and the release assembly sear. (paragraph #15 picture #30)





# GMV ATM

## Parts Book



# **Table of Contents**

Elevator assembly	Page 2
Release assembly	Page 3
Feed port assembly	Page 4
Windage assembly	Page 5
Height adjustment rod for wobble	Page 6
Magazine assembly	Page 7
Brush pack assembly	Page 8
Chain adjustment sprocket	Page 9
Main spring assembly	Page 10
Turnbuckle assembly	Page 11
Main motor assembly	Page 12
Throwing table with target guide rails	Page 13
Throwing table target separator	Page 14
Main shaft assembly	Page 15
Text main shaft	Page 16
Inner target retainer wheel	Page 17
Oscillation base	Page 18
Outer retainer wheel assembly	Page 19
Electric circuit	Page 20
Electric circuit	Page 21
Electric schematics	Page 22
Electric schematics	Page 23
Electric over view	Page 24

# Parts Book

Parts # **1000**

Elevator assembly

GMV ATM

Pos	Amt.	Parts Number	Parts Name	Price	Price
1	1	100-1	Elevator Bracket Rear	0	0
2	2	M6S 6x20 H	Bolt	0	0
3	1	1000-3	Spring	0	0
4	1	1000-4	Elevator arm - upper	0	0
5	1	1000-5	Elevator arm - lower	0	0
6	1	1000-6	Elevator bracket - front	0	0
7	3	MC6S 6x20 H	Bolt	0	0
8	5	BRB 6.4x12x1.6	Washer	0	0
9	2	MC6S 6x12	Bolt	0	0
10	2	1000-10	Elevator	0	0
11	1	1000-11	Elevator holder	0	0
12	2	M6S 10x50	Bolt	0	0
13	8	BRB 10x18x2	Washer	0	0
14	7	6000 2 RS	Bearing	0	0
15	2	1000-15	Spacer	0	0
16	1	1000-16	Bearing shaft	0	0
17	2	M6S 10x25	Bolt	0	0
18	1	35.5x18.3x0.9 nr.4327	Spring washer	0	0

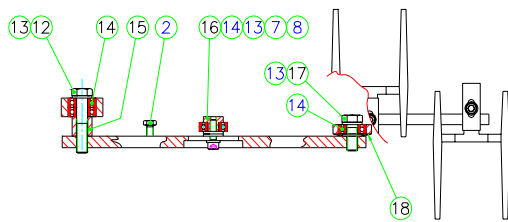
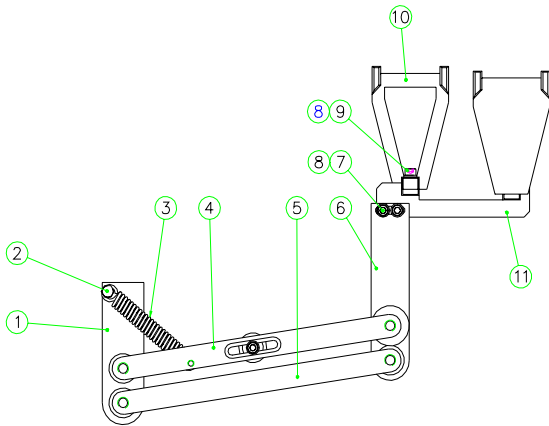

# Parts book

Parts # **1800**

Release assembly

GMV ATM

Pos	Amt.	Parts Number	Parts Name	Price	Price
1	1	1800-1	Sear		
2	1	1800-2	Trigger plate		
3	1	1800-3	Electromagnet assembly		
4	1	1800-4	Electromagnet		
5	1	1800-5	Electromagnet housing		
6	2	MC6S 5x25H	Bolt		
7	2	BRB 5.3x10x1	Washer		
8	2	6000 2 RS	Bearing		
9	4	BRB 10x18x2	Washer		
10	1	M6S 10x40	Bolt		
11	1	FRP 8x40	Pin		
12	2	MC6S 6x30H	Washer		
13	2	BRB 6.4x12x1.6	Bolt		
14	1	1800-14	Steel plate for buffer		
15	1	1800-15	Buffer		
16	1	1800-16	Skirt		

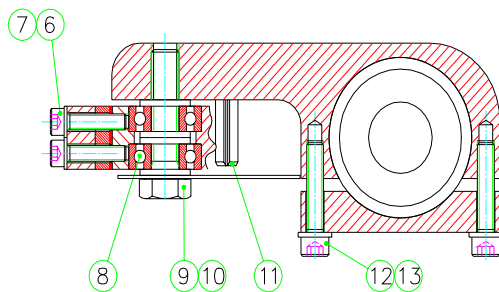
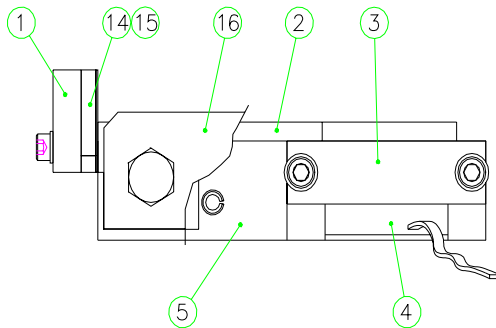

# Parts book

# **2200**

Feed port assembly

GMV ATM

Pos	Amt.	Parts Number	Parts Name	Price	Price
1	1	2200 -1	Feed port plate		
2	1	2200 -2	Feed port shaft		
3	2	MC6S 4x8	Bolt		
4	1	2200 -4	Feed port		
5	1	2200 -5	Washer		
6	2	MC6S 8x35	Bolt		
7	2	BRB 8.4x16x1.6	Washer		
8	1	Gn 617 NIK 8	Turn knob		
9	1	Gn 617.6 NI 8	Nut		
10	1	2200 -10	Lock bracket		
11	2	MC6S 6x20 H	Bolt		
12	2	BRB 6.4x12x1.6	Washer		
13	1	2200 -13	Turn knob bracket		
14	3	6000 2 RS	Bearing		
15	1	ML6M 10	Bolt		
16	1	2200-16	Spacer		

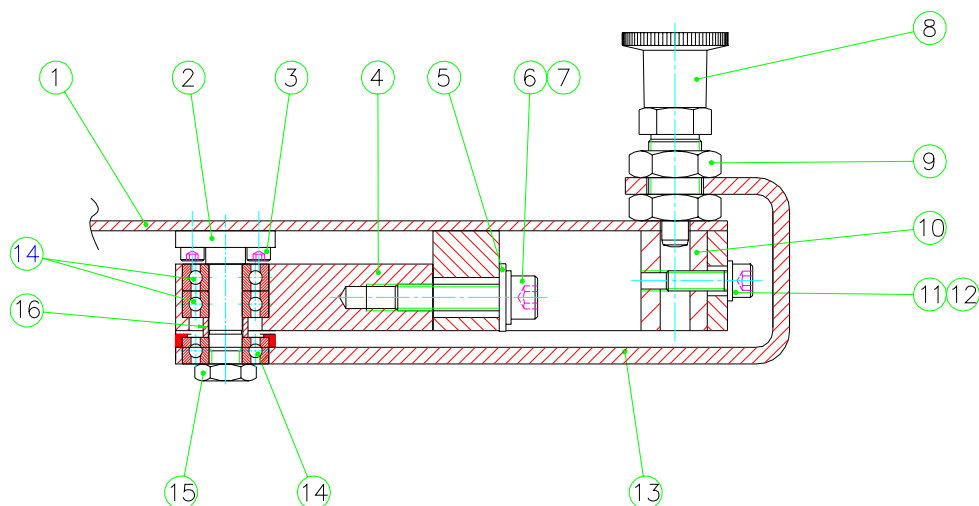

# Parts book

# **2500**

Windage

GMV ATM

Pos	Amt.	Parts Number	Parts Name	Price	Price
1	1	2500-1	Windage plate - upper		
2	1	GN 617 NIK 6	Windage adjustment knob		
3	2	M6S 8x20H	Bolt		
4	2	BRB 8.4x16x1.6	Washer		
5	1	2500-5	Windage plate - lower		
6	1	2500-6	Windage link		
7	1	GE 12 C	Bearing		
8	1	60E8/68r7x8	Bronze bushing		
9	1	2500-9	Centre windage hub		
10	1	6000-2RS spec.	Bearing		
11	2	M6S 8x16	Bolt		
12	2	BRB 8.4x16x1.6	Washer		
13	1	5006-6	Thumb screw		

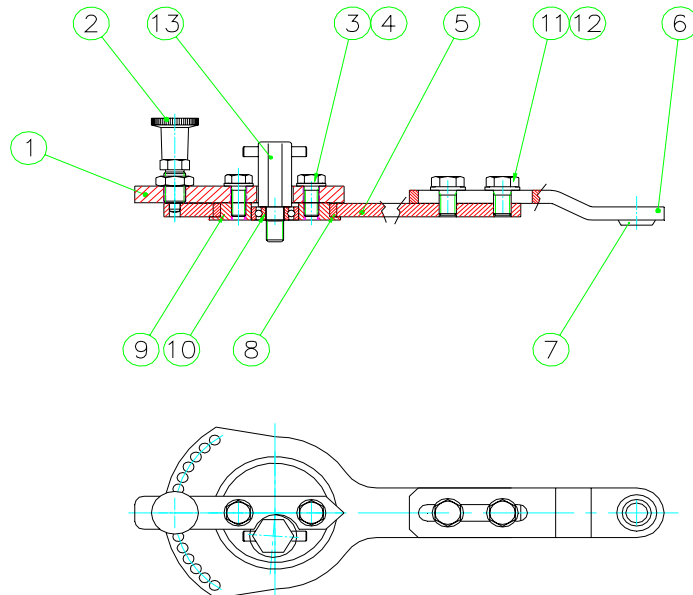

# Parts book

# **3003**

Arm assembly for wobble trap.

GMV ATM

Pos	Amt.	Parts Number	Parts Name	Price	Price
1	1	GE 10 C	Bearing		
2	1	3003-2	Arm		
4	1	M6LM M12	Bolt		
5	1	RF 12	Link head		
6	1	13x24x5,5	Washer		
7	1	MC6S M12x35	Bolt		
8	1	M6LM M12	Nut		
9	1	BRB M12	Washer		
10	1	3003-10	Bracket		

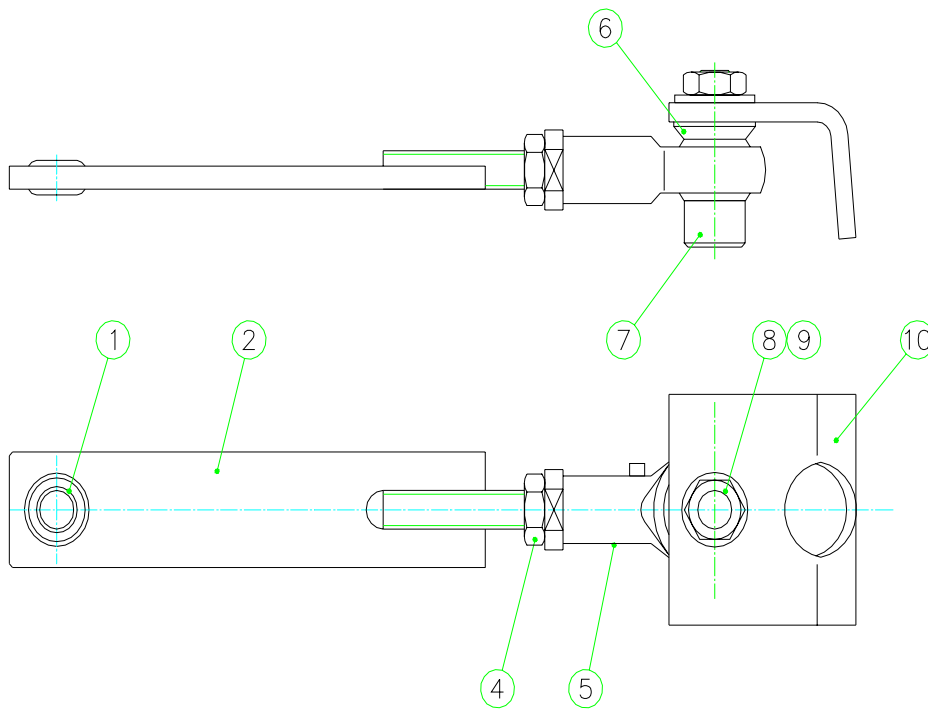

# Parts Book

Parts # **300**

Magazine Assembly

Pos	Amt	.Parts Number	Parts name	Price	Price
1	18	MRT-TT M4x8	Screw		
2	1	300-2	Magazine ring - upper		
3	1	300-3	Magazine base		
4	1	300-4	Magazine release lever		
5	4	MC6S 8x25	Bolt		
6	8	BRB 8.4x16x1.6	Washer		
7	4	M6M 8	Bolt		
8	2	300-8	Bronze bushing.		
9	1	300-9	Magazine shaft - upper		
10	1	300-10	Magazine shaft housing - upper		
11	2	FRP 5x12	Bolt		
12	2	300-12	Bronze bushing		
13	1	300-13	Brass plate		
14	1	300-14	Geneva lock		
15	1	300-15	Magazine shaft housing - lower		
16	4	MC6S 6x20 H	Bolt		
17	4	BRB 6.4x12x1.6	Washer		
18	4	MC6S 8x35 H	Bolt		
19	1	300-19	Nut plate		
20	1	300-20	Magazine shaft - lower		
21	4	FRP 4x16	Bolt		
22	2	T6SS M8x10	Bolt		
23	1	300-23	Timing gear		
24	4	MC6S 10x35	Bolt		
25	6	BRB 10x18x2	Washer		
26	1	300-26	Nut plate		
27	1	300-27	Sprocket		
28	1	SMS 2306 8x7-20	Key		
29	1	300-29	Timing gear shaft		
30	4	SgA 25	Lock ring		
31	1	300-31	Chain		
32	1	300-32	Chain lock		
33	1	300-33	Timing gear housing		
34	1	3205 2RS	Bearing		
35	36	300-35	Pin		
36	1	6000 2RS	Bearing		
37	1	MC6S 10x30 H	Bolt		
38	18	300-38	Magazine profile		

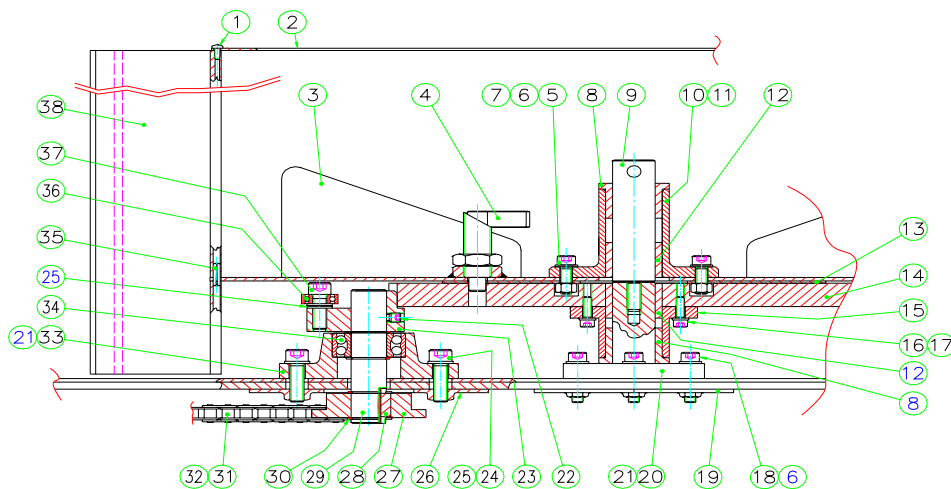



# Parts book

# **3300**

Brush pack assembly

GMV ATM

Pos	Amt.	Parts Number	Parts Name	Price	Price
1	2	MC6S 6x20H	Bolt		
2	1	3300-2	Brush holder		
3	1	3300-3	Brush shaft		
4	2	MC6S 6x30	Bolt		
5	1	3300-5	Rod		
6	1	MC6S 6x16	Bolt		
7	1	3300-7	Brush pack		
8	1	M6x25	Bolt		

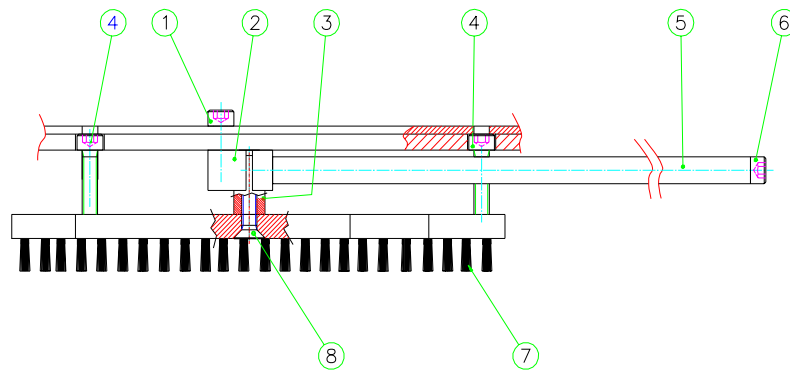

# Parts book

# **4000**

Chain adjustment sprocket

GMV ATM

Pos	Amt.	Parts Number	Parts name	Price	Price
1	1	M6M 10	Nut		
2	3	BRB 10x18x2	Washer		
3	1	4000-3	Sprocket		
4	1	4000-4	Spacer		
5	2	6000 2RS	Bearing		
6	1	M6S 10x50	Washer		

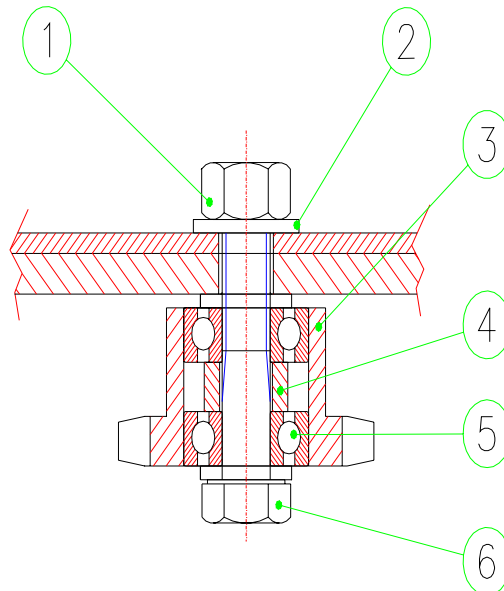

# Parts book

# **4200**

Main spring rear assembly

GMV ATM

Pos	Amt.	Parts Number	Parts Name	Price	Price
1	1	M16x120	Threaded rod		
2	2	M6M 16	Nut		
3	1	4200-3	Shaft		
4	1	4200-4	Washer		
5	1	4200-5	Eyelet		
	1	4200-6	Main spring		

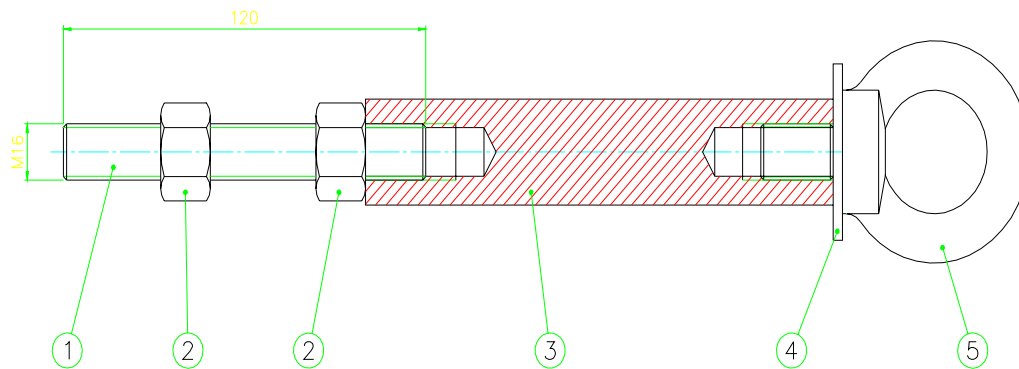

# Parts book

# **4500**

Turnbuckle assembly

GMV ATM

Pos	Amt.	Parts Number	Parts name	Price	Price
1	1	4500-1	Bracket		
2	2	MC6S 12x35	Bolt		
3	1	BRB 12	Washer		
4	1	4500-4	Thraeded rod		
5	2	4500-5	Elevation nut		
6	1	M6LM M12	Nut		
7	1	GE 12 C	Bearing		
8	1	4500-8	Link head		
9	2	4500-9	Lock plate		

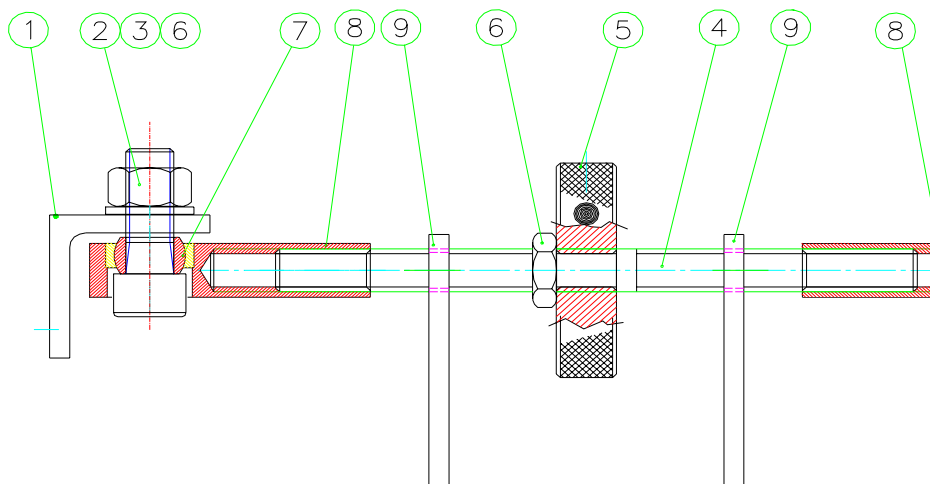

# Parts book

# **5003**

Main Motor Assembly

GMV ATM

Pos	AMT	Parts Number	Parts Name	Price	Price
1	6	M6M 10	Nut		
2	12	BRB 10x18x2	Washer		
3	2	MGS 10x55	Bolt		
4	4	MC6S 6x20H	Bolt		
5	4	BRB 6.4x12x1.6	Washer		
6	1	5003-6	Cover		
7	1	MRX-Z M3x4	Screw		
8	1	5003-8	Swedrive gear box		
9	1	5003-9	O - Ring 69.5x5.7		
10	1	5003-10	Electro magnetic clutch		
11	1	5003-11	Nylon washer		
12	1	MT6SS M6x12	Bolt		
13	1	5003-13	Motor bracket		
14	4	MC6S 10x20H	Bolt		
15	1	5003-15	Main motor		

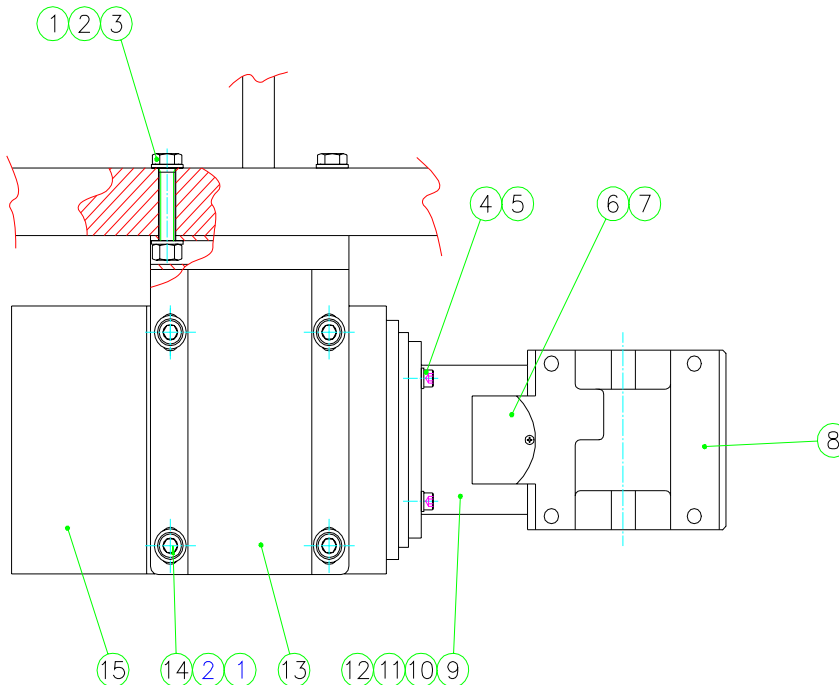

# Parts Book

# **5004**

Throwing table

GMV ATM

Pos	Amt.	Parts Number	Part Name	Price	Price
1	1	5004-1	Single target lever assembly		
2	1	5004-2	Nut		
3	1	5004-3	Nut		
4	1	5004-5	Bracket		
5	3	5004-5	Lock ring SGA 10		
6	4	10E7/16x10	Bushing		
7	1	5004-7	Bracket - inner		
8	1	5004-8	Rod		
9	1	5004-9	Bearing block		
10	4	MC6S 6x20	Bolt		
11	4	BRB 6.4x12x1.6	Washer		
12	1	Wn 450 50-M10	Turn knob		
13	3	M6M 10	Bolt		
14	1	5004-14	Spring		
15	4	BRB 10x18x2	Washer		
16	1	5004-16	Bearing block		
17	1	5004-17	Adjustment rod		
18	1	5004-18	Threaded adjustment rod		
19	2	M6M 6	Bolt		
20	1	5004-20	Target guide rail - double		
21	1	5004-21	Target guide rail - single		
22	1	5004-22	Guide rail holder		
23	2	BRB 10.5x18x1.6	Washer		
24	2	MC6S 5x12 H	Bolt		
25	12	M6M 8	Nut		
26	6	MF6S 8x50 H	Bolt		
27	6	5004-27	Table adjustment spacer		
28	1	5004-28	Table		
29	1	5004-29	Stop rod		
30	1	BRB 6,4x12x1,6	Washer		
31	1	M6M M6	Lock nut		
32	1	6,3x2,4	O-Ring		
33	2	5x20	Bolt		
34	2	BRB M5	Washer		
35	1	5004 -34.	Target separator		

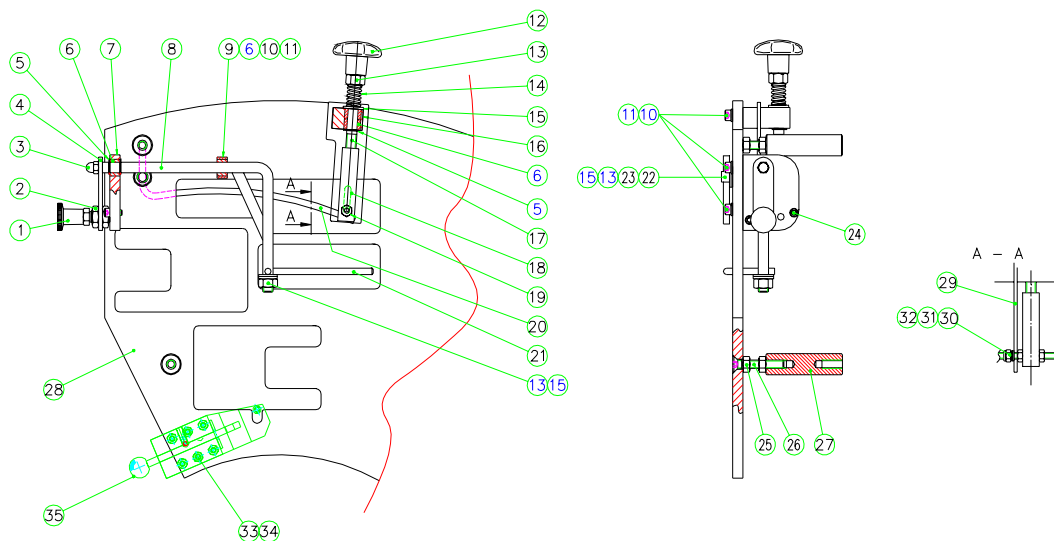

# Parts book

# **6000**

Namn:

Target separator

GMV ATM

Pos	Amt.	Parts Number	Parts name	Price	Price
1	1	M6	Knob		
2	1	6000-2	Brass rod		
3	1	6000-3	Guide plate		
4	4	M5x8	Bolt		
5	1	FRP 2x16	Pin		
6	1	6000-6	Leafspring guide		
7	1	6000-7	Rod		
8	1	M5x8	Bolt		
9	1	M6	Lock screw		

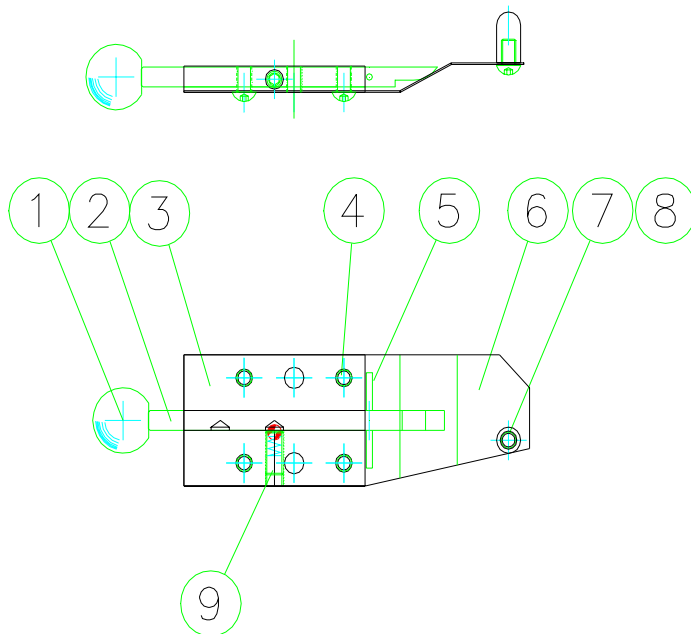

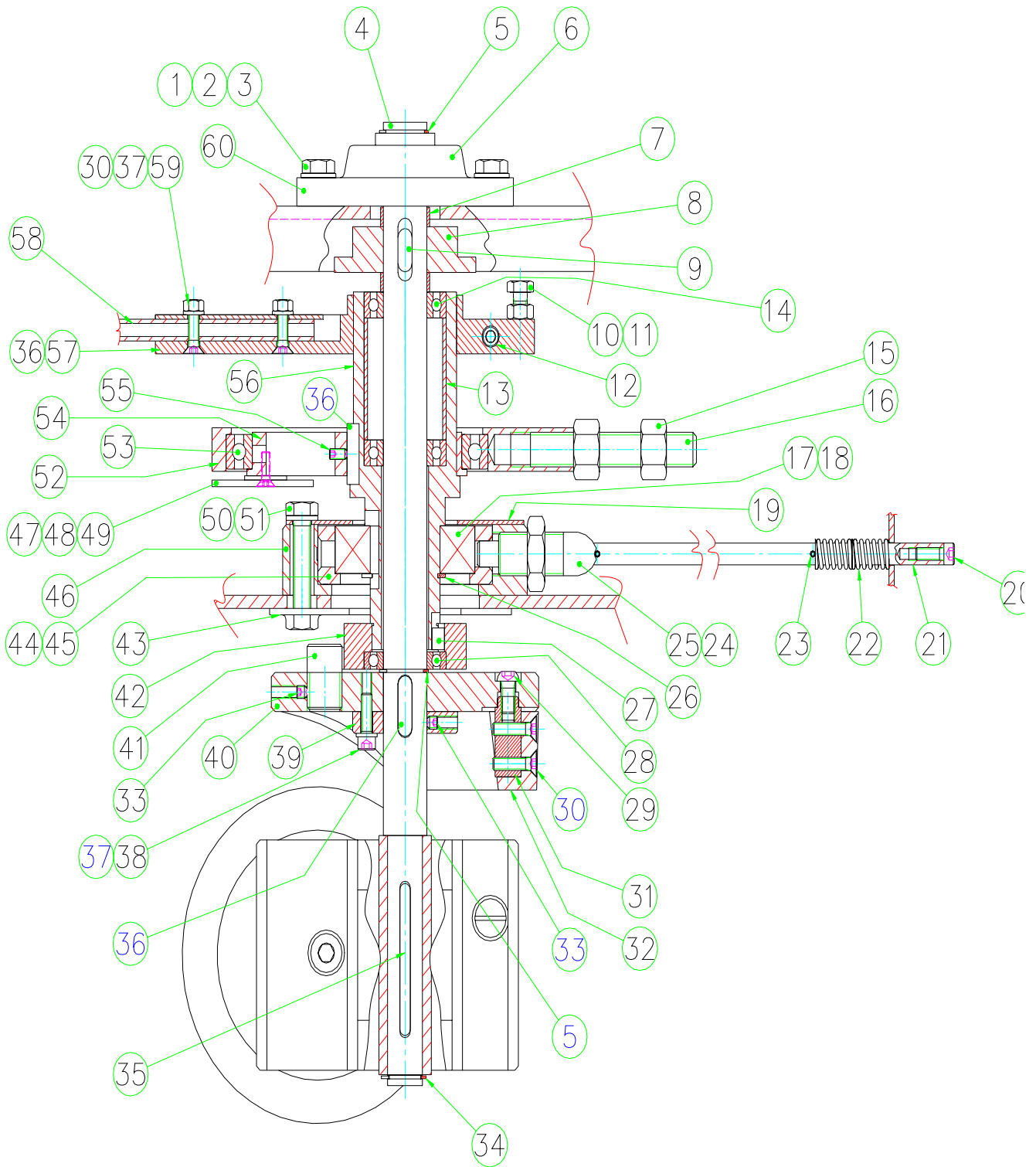



# Parts book

# **5002**

Name:

Main shaft Assembly

GMV ATM

Pos	Amt.	Parts Number	Parts Name	Price	Price
1	2	M6M 10	Bolt		
2	4	BRB 10.5x22x2	Washer		
3	2	M6S 10x25H	Bolt		
4	1	5002-4	Main shaft		
5	2	5002-5	Lock ring		
6	1	5002-6	Bearing		
7	2	5002-7	Spacer		
8	1	5002-8	Sprocket		
9	1	5002-9	Key		
10	1	M6S 8x25	Bolt		
11	1	M6M 8	Nut		
12	1	MC6S 6x40	Allen bolt		
13	1	5002-13	Shaft		
14	2	5002-14	Bearing		
15	2	M6M 16	Nut		
16	1	M16x95	Threaded rod		
17	1	5002-17	One way bearing		
18	1	5002-18	Key		
19	1	5002-19	Plate		
20	1	MC6S 6x16	Bolt		
21	1	5002-21	Release rod		
22	2	5002-22	Spring		
23	2	5002-23	Spring		
24	1	GN617.6 10	Nut		
25	1	GN612 A12	Release assembly		
26	1	5002-26	Lock ring SGA 40		
27	1	5002-27	Key		
28	1	5002-28	Bearing		
29	1	MK6S 8x16	Bolt		
30	4	MF6S 6x20	Bolt		
31	1	5002-31	Cam shaft		
32	1	5002-32	Cam		
33	2	SK6SS 6x6	Bolt		
34	1	5002-34	Lock ring SGA 20		
35	1	SMS 2306 6x6-70 R	Key		
36	3	SMS 2306 8x7-28 R	Key		
37	6	BRB 6.4x12x1.6	Washer		
38	4	MC6S 6x20	Bolt		
39	1	5002-39	Spacer		
40	1	5002-40	Cocking assembly		
41	1	5002-41	Cocking shaft		
42	1	5002-42	Spacer		
43	1	5002-432	Nut plate		
44	1	SMS 2306 10x8-25T	Key		
45	1	5002-45	Outer one way bearing ring		
46	1	5002-46	Outer one way bearing housing		
47	2	BRB 13x24x2	Washer		
48	2	MF6S 5x12	Bolt		
49	1	5002-49	Trigger plate		
50	3	BRB 18x10x2	Washer		
51	3	M6S 10x50	Bolt		
52	1	5002-52	Housing for main spring bearing		
53	1	61824-2RS	Bearing		
54	1	5002-54	Main spring excenter		
55	1	SK6SS M5x10	Allen screw		
56	1	5002-56	Outer main shaft		
57	1	5002-57	Throwing arm holder		
58	1	5002-58	Throwing arm		
59	2	M6M 6	Bolt		
60	2	FRP 4x16	Bolt		

# Parts book

# **5005**

Target retainer wheel - inner

GMV ATM

Pos	Amt.	Parts Number	Parts Name	Price	Price
1	1	5005-1	O - Ring 75.0x5.0		
2	1	5005-2	Retainer wheel		
3	2	BRB 10x18x2	Washer		
4	1	5005-4	Lock ring SGA 15		
5	1	5005-5	Retainer wheel arm		
6	1	MC6S 6x25	Bolt		
7	2	BRB 6.4x12x1.6	Washer		
8	3	M6M 6	Nut		
9	1	5005-9	Steel bushing		
10	1	5005-10	Bronze bushing 10E7/ 16x10		
11	1	5005-11	Spring ( GMV 25)		
12	1	MC6S 6x35	Bolt		
13	1	5005-13	Target guide finger		

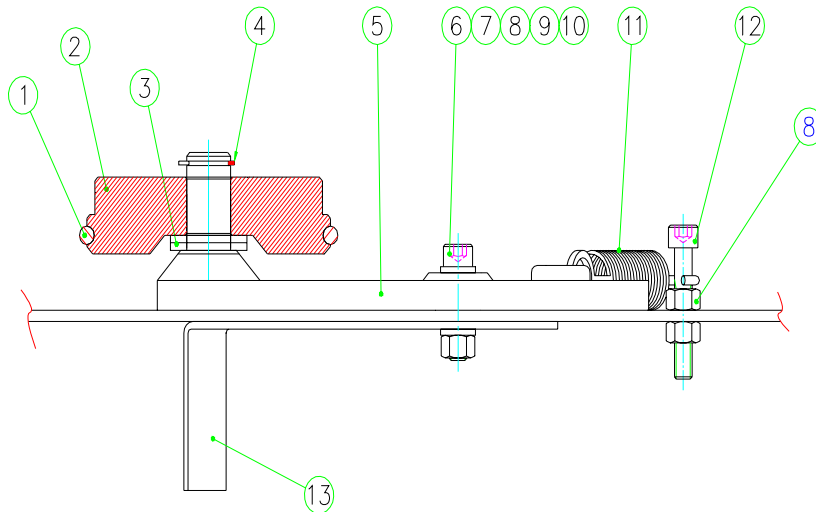

# Parts book

# **5006**

Oscillation base

GMV ATM

Pos	Amt.	Parts Number	Parts Name	Price	Price
1	1	5006-1	Motor with gear box		
2	12	BRB 6.4x12x1.6	Washer		
3	4	MC6S 6x20H	Bolt		
4	1	5006-4	Angle change disc		
5	1	SK6SS M6x6	Allen Bolt		
6	1	5006-6	Thumb screw		
7	1	5006-7	Windage assembly		
8	1	M6S 12x30	Bolt		
9	4	MC6S 6x30	Bolt		
10	1	5006-10	Angle crank		
11	1	5006-11	Oscillation shaft		
12	1	5006-12	Shaft nut		
13	1	5006-12	Spacer		
14	1	5006-13	Seal		
15	2	M6M 10	Nut		
16	6	BRB 10x18x2	Washer		
17	1	5006-17	Link head		
18	1	5006-18	U-Bracket		
19	2	5006-19	Bearing		
20	2	M6S 10x30H	Bolt		
21	2	M6S 6x25H	Nut		
22	2	M6M 6	Bolt		
23	2	5006-23	Bearing		
24	7	MC6S 8x16	Bolt		
25	1	5006-25	Spacer		
26	1	5006-26	Base		
27	1	5006-27	Threaded rod		
28	1	MHM M10	Nut		
29	3	M6S 10x25H	Bolt		
30	1	5006-30	Oscillation base		

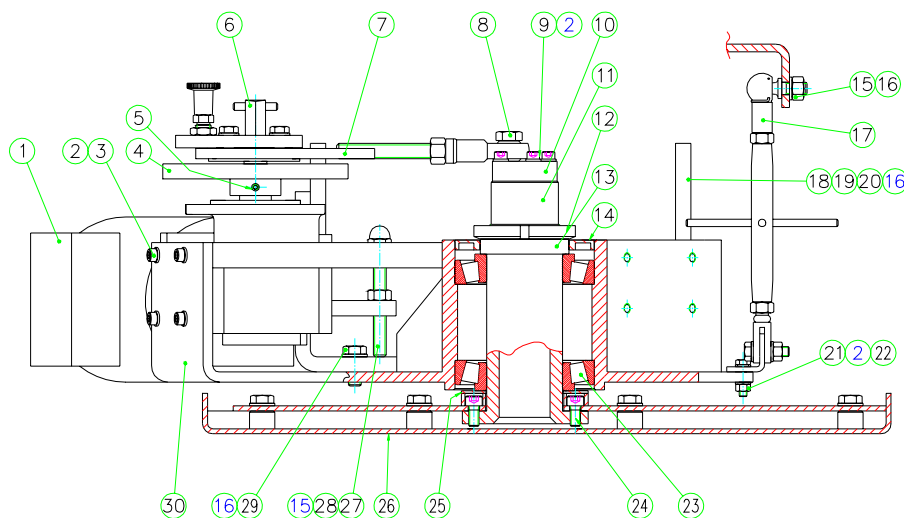

# Parts book

# **5007**

Outer target retainer wheel

GMV ATM

Pos	Amt.	Parts Number	Parts Name	Price	Price
1	2	5007-1	Leaf spring		
2	2	5007-2	Leaf spring bracket		
3	3	M6M 6	Bolt		
4	4	BRB 6.4x12x1.6	Washer		
5	2	MC6S 6x16H	Nut		
6	4	MC6S 8x20	Bolt		
7	8	BRB 8.4x16x1.6	Washer		
8	4	5007-8	Shaft		
9	4	SgA 15	Lock ring		
10	8	BRB 15x26x2	Washer		
11	4	5007-11	Retainer wheel		
12	8	5007-12	O - Ring 23.40 x 3.53		
13	1	MC6S 6x20	Bolt		
14	4	M6M M8	Nut		
15	1	DIN 985 M8	Nut		
16	2	M6M 8	Bolt		
17	1	MC6S 8x30	Bolt		
18	1	5007-18	Retainer wheel plate		
19	1	5007-19	Spacer		
20	1	MC6S 8x35	Bolt		

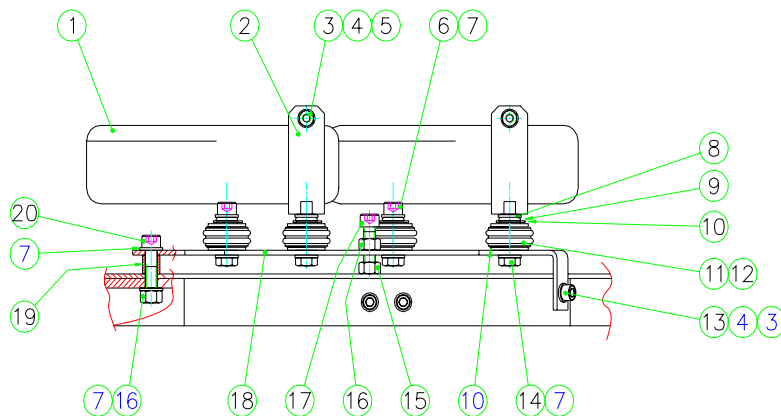

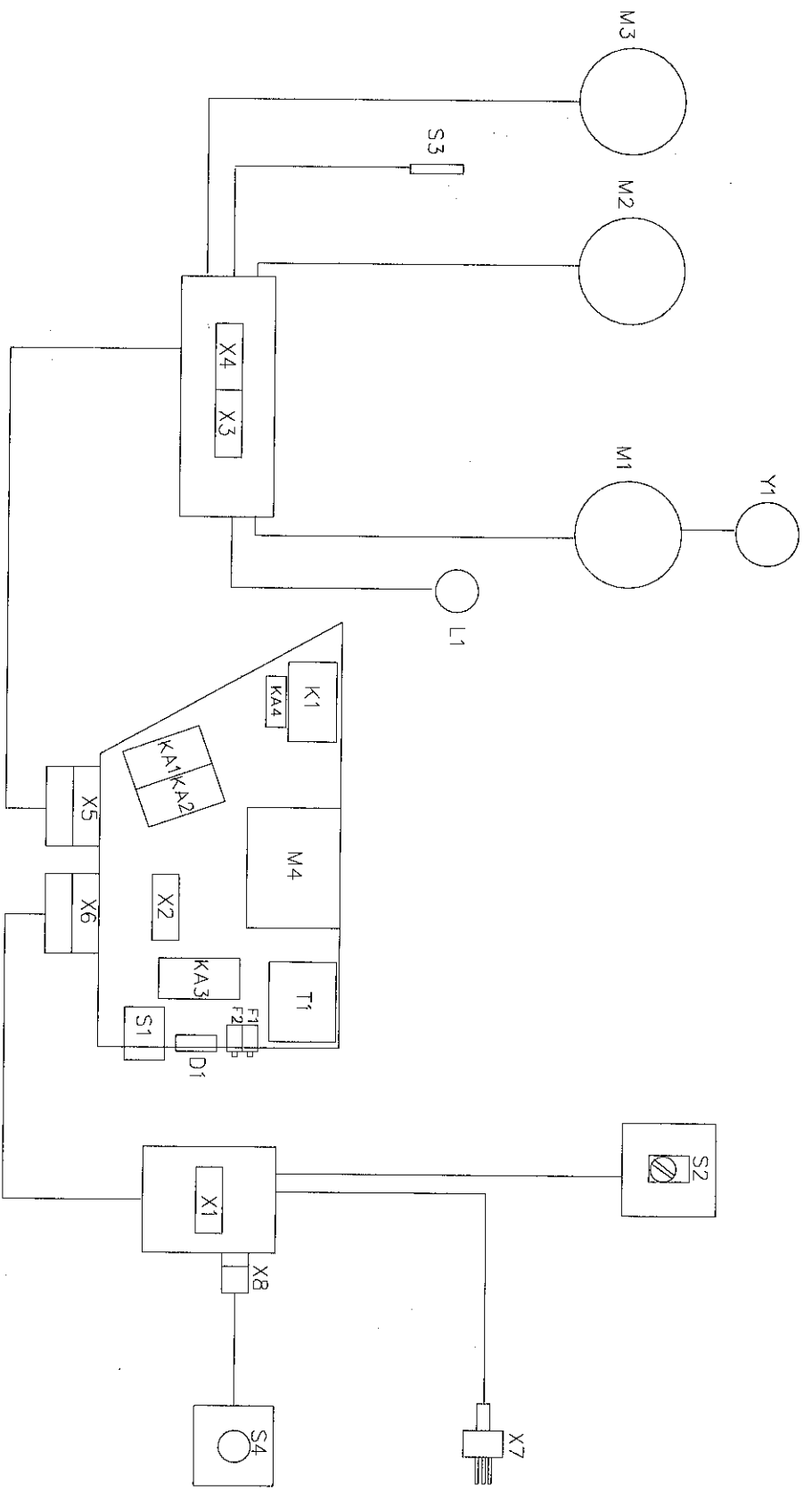

<b>GMV SUPER STAR</b>		<b>GMV ATM</b>	
DRAWING	DATE	PAGE	OF
FILE GMV1_1	OVERVIEW	1	6
		PAGE	OF
		1	6

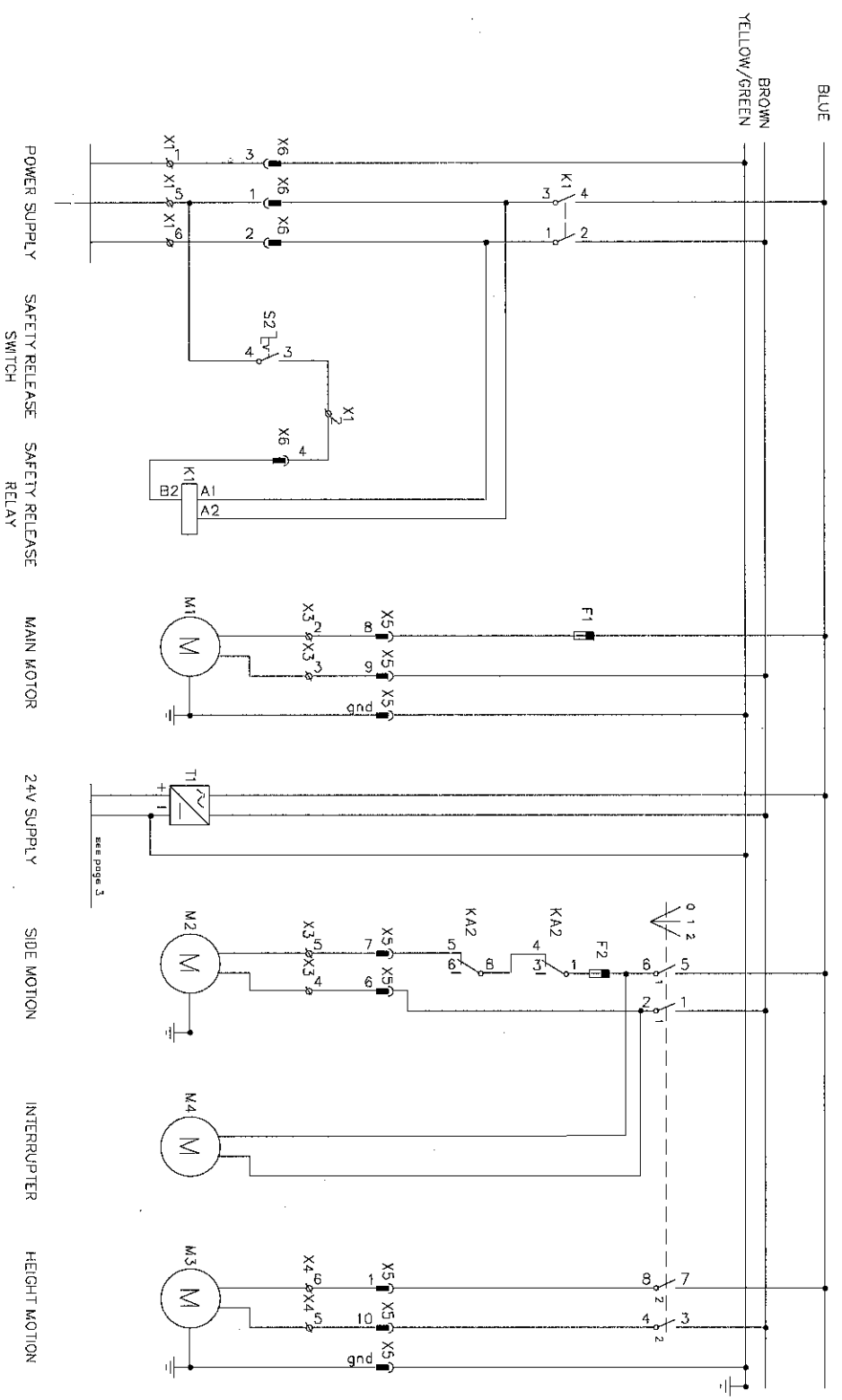

POWER SUPPLY SAFETY RELEASE SWITCH SAFETY RELEASE RELAY MAIN MOTOR 24V SUPPLY SIDE MOTION INTERRUPTER HEIGHT MOTION

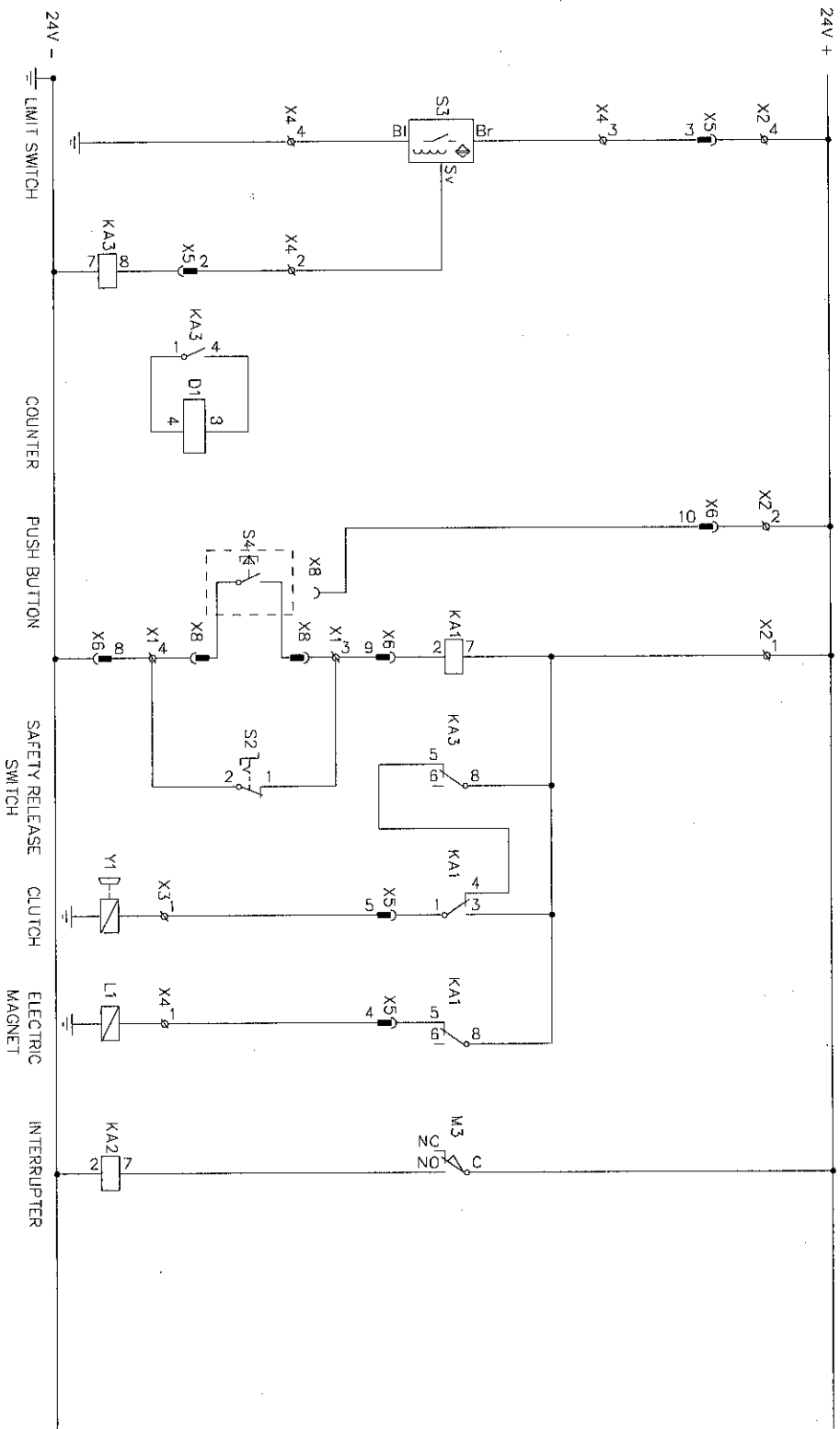

<b>GMV SUPER STAR</b>	
DRAWING 24V CIRCUITS	DATE 990601
FILE GMV - 3	PAGE 3 OF 6

GMV ATM

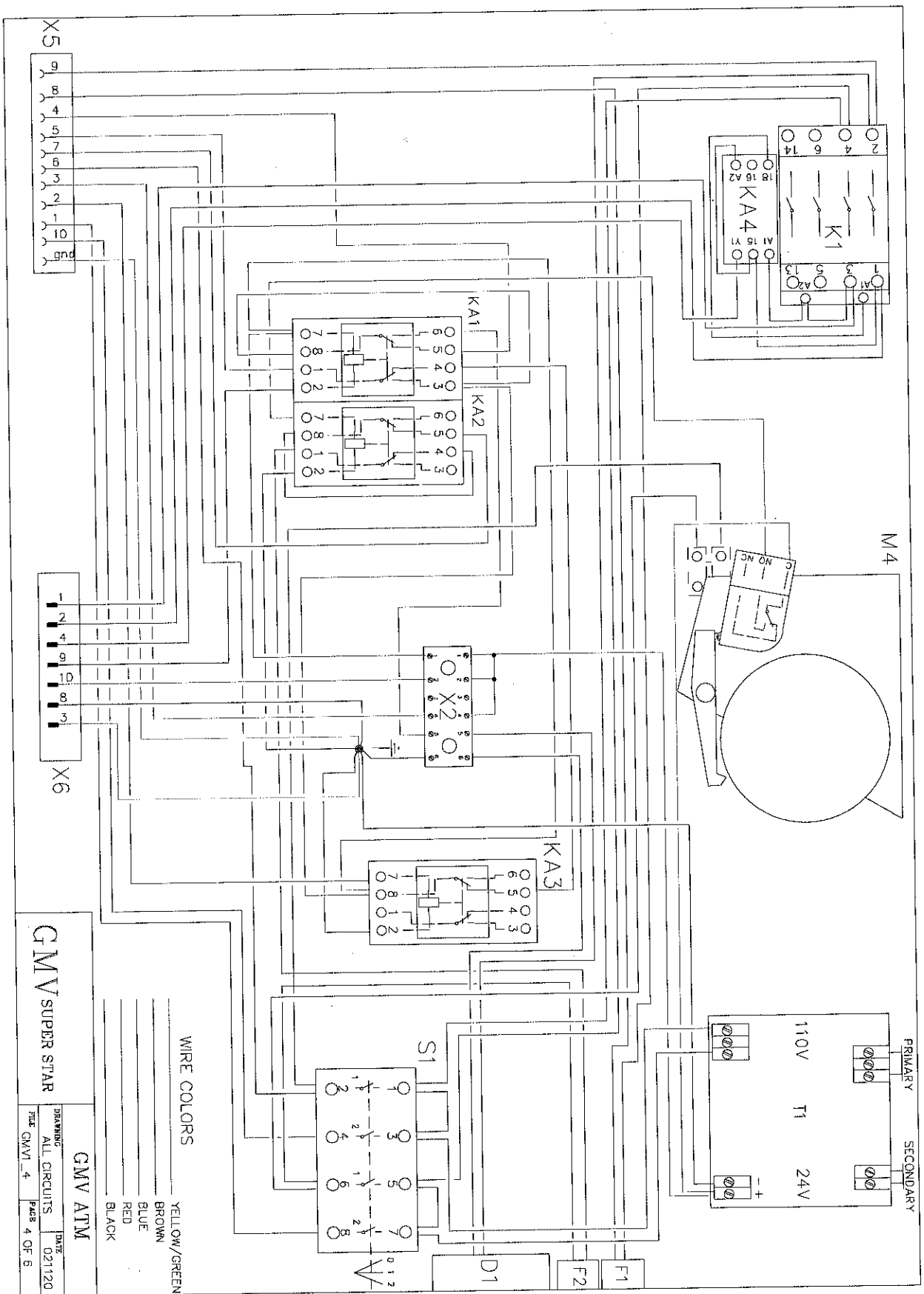

WIRE COLORS

- YELLOW/GREEN
- BROWN
- BLUE
- RED
- BLACK

GMV SUPER STAR

GMV ATM

DRAWING: ALL CIRCUITS 0211120  
 FILE: GMV1\_4 Page 4 OF 6



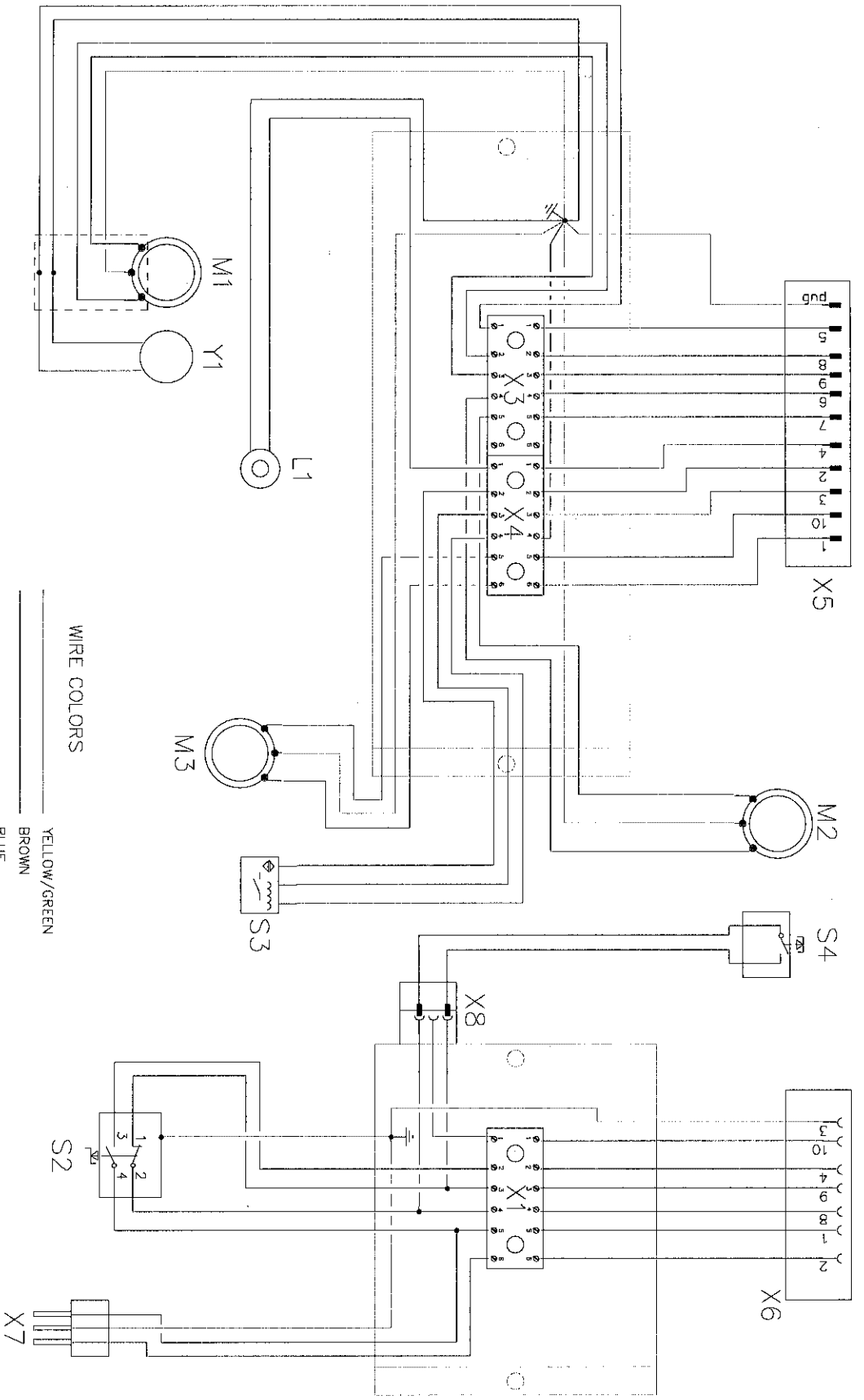

WIRE COLORS

- YELLOW/GREEN
- BROWN
- BLUE
- RED
- BLACK

GMV SUPER STAR

GMV ATM

DRAWING	DATE
ALL CIRCUITS	990601
FILE GMV_5	PAGE 5 OF 6

TERM	NAME	TYPE	PARTS LIST NUMBER	DATA	NOTE
M1	MOTOR				MAIN MOTOR
M2	MOTOR				SIDE MOTOR
M3	MOTOR				HEIGHT MOTION
M4	INTERRUPTER				SIDE MOTION
S1	SWITCH				SIDE MOTOR
S2	SWITCH				SAFETY RELEASE
S3	LIMIT SWITCH				
S4	PUSH BUTTON				
X1	WIRE CONNECTOR				
X2	WIRE CONNECTOR				
X3	WIRE CONNECTOR				
X4	WIRE CONNECTOR				
X5	CONNECTING PLUG				
X6	CONNECTING PLUG				
X7	CONNECTING PLUG				POWER SUPPLY
X8	CONNECTING PLUG				
Y1	CLUTCH				
C1	COUNTER				
K1	RELAY AND TIME RELAY				SAFETY RELEASE
KA1	RELAY AND SOCKET				
KA2	RELAY AND SOCKET				
KA3	RELAY AND SOCKET				
KA4	TIME RELAY				
T1	TRANSFORMER AND CIRCUIT BOARD				
L1	ELECTRIC MAGNET				
F1	FUSE				MAIN MOTOR
F2	FUSE				SIDE MOTION

GMV SUPER STAR

GMV ATM

DIAGRAM COMPONENTS 590601  
 FILE GMV\_6 PAGE 6 OF 6