

GMV SUPER STAR

GMV 455:110

DATE 021120

OVERVIEW

FILE GMV455-110\_1

PAGE 1 OF 4

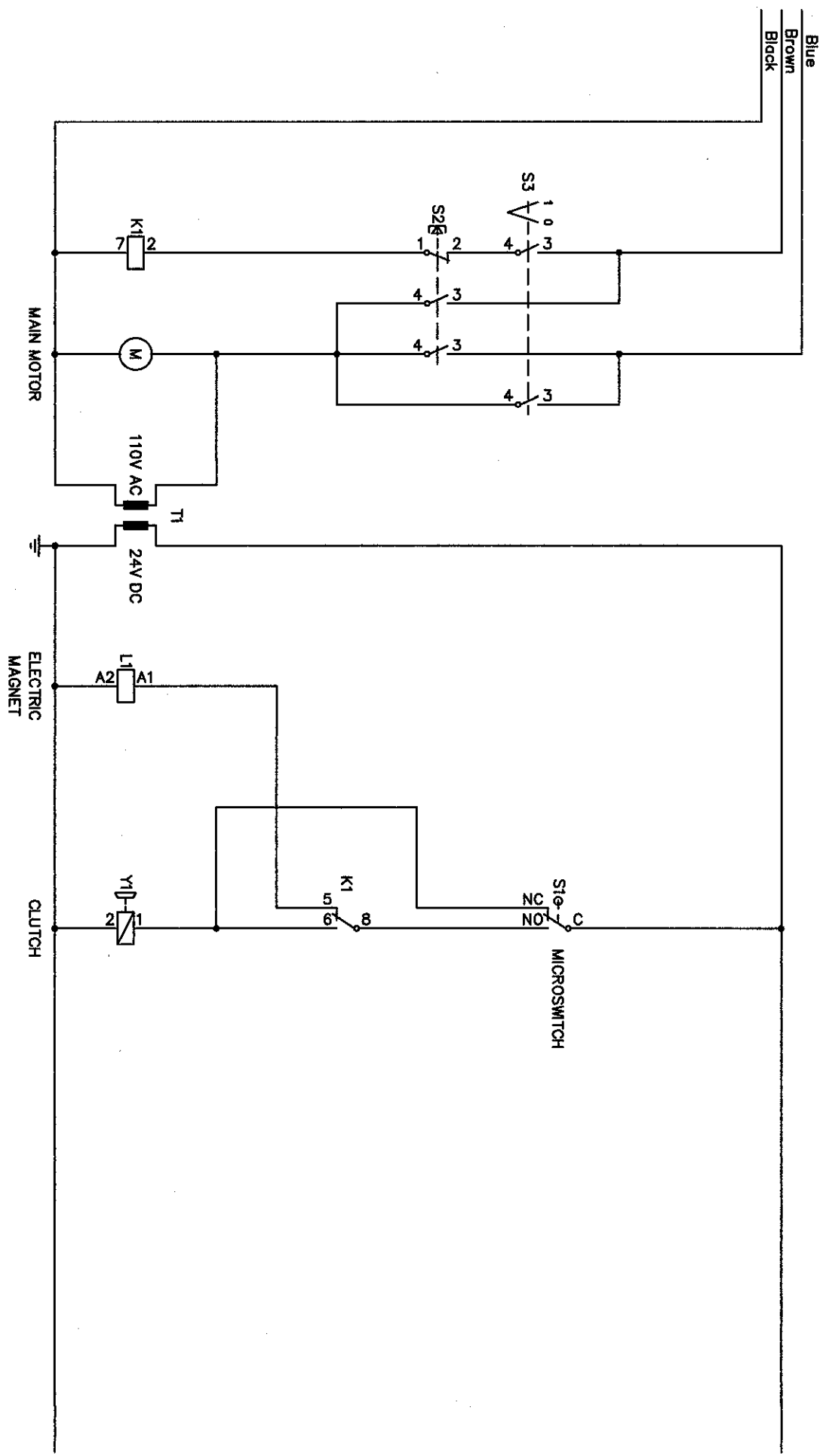

Blue  
Brown  
Black

GMV SUPER STAR

GMV 455:110

ALL CIRCUITS  
GMV455-110 2  
2 OF 4

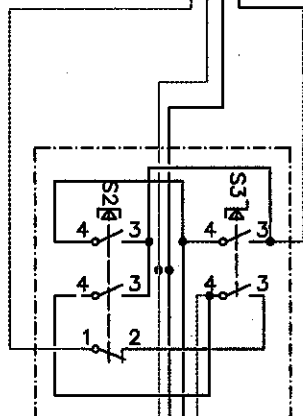
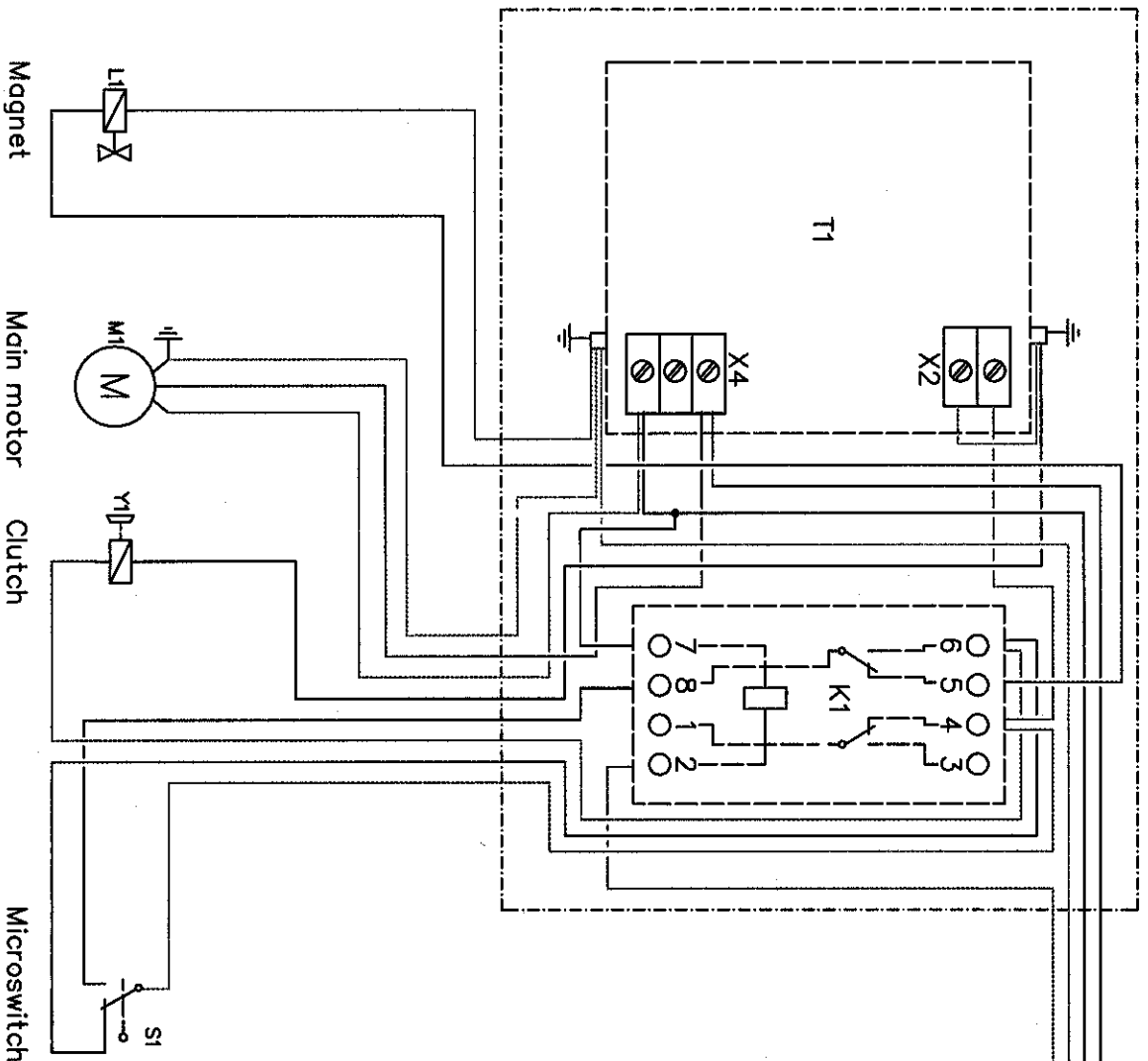

Safety release

Power supply

<h1>GMV SUPER STAR</h1>		<b>GMV 455: 110</b>	
		<small>DATE</small> 02/11/01	<small>DESIGNED BY</small> ALL CIRCUITS
<small>PAGE</small> 3 OF 4		<small>GMV 455-110_3</small>	

TERM	NAME	TYPE	PARTS LIST NUMBER	DATA	NOTE
M1	MOTOR				MAIN MOTOR
S1	MICROSWTICH				SAFETY RELEASE
S2	PUSH BUTTON				SAFETY RELEASE
S3	SWTICH				SAFETY RELEASE
Y1	CLUTCH				
K1	RELAY AND SOCKET	C2-A20	GMV 150	C2-A20 DC24V	
T1	TRANSFORMER AND CIRCUIT BOARD	115V-24V	GMV 143-2 / GMV 153-2		110V/24V
L1	ELECTRIC MAGNET				

**GMV SUPER STAR**

---

**GMV 455:110**

REWORKING COMPONENTS

GMV455-110-4 PAGE 4 OF 4

DATE 021120